

CLASSIFICATION	PRODUCT SPECIFICATION	No. DS-13xx-2400-102	REV. 5.1
SUBJECT	CLASS 1 or 2 BLUETOOTH MODULE	PAGE	2 of 55
CUSTOMER'S CODE PAN13XX Core Specification	PANASONIC'S CODE See Chapter Ordering Information	DATE	08.11.2017

TABLE OF CONTENTS

1	About this document.....	4
1.1	Purpose.....	4
1.2	Revision History.....	4
1.3	Related Documents.....	5
1.4	General Information.....	5
1.5	Contact Us.....	6
2	New PAN13x5B, PAN13x6B.....	7
3	Key Features.....	8
4	Applications for the Module.....	8
5	Description for the Module.....	9
6	Detailed Description.....	10
6.1	Terminal Layout.....	10
6.2	Pin Description.....	11
6.3	Device Power Supply.....	12
6.4	Clock Inputs.....	14
7	Bluetooth Features.....	14
8	Block Diagram.....	15
9	Test Conditions.....	16
10	General Device Requirements and Operation.....	16
10.1	Absolute Maximum Ratings.....	16
10.2	Recommended Operating Conditions.....	17
10.3	Current Consumption.....	17
10.4	General Electrical Characteristics.....	18
10.5	nSHUTD Requirements.....	18
10.6	External Digital Slow Clock Requirements.....	18
11	Host Controller Interface.....	19
12	Audio/Voice Codec Interface.....	20
12.1	PCM Hardware Interface.....	20
12.2	Data Format.....	20
12.3	Frame Idle Period.....	21
12.4	Clock-Edge Operation.....	21
12.5	Two-Channel PCM Bus Example.....	22
12.6	Audio Encoding.....	22
12.7	Improved Algorithm For Lost Packets.....	22
12.8	Bluetooth/PCM Clock Mismatch Handling.....	23
12.9	Bluetooth Inter-IC Sound (I2S).....	23
12.10	Current Consumption for Different Bluetooth Scenarios.....	23
13	Bluetooth RF Performance.....	24
14	Soldering Temperature-Time Profile (for reflow soldering).....	27
14.1	For leadfree solder.....	27
15	Module Dimension.....	28
15.1	Module Dimensions PAN131X without Antenna.....	28
15.2	Module Dimensions PAN132X with Antenna.....	29
16	Footprint of the Module.....	30

CLASSIFICATION	PRODUCT SPECIFICATION	No. DS-13xx-2400-102	REV. 5.1
SUBJECT	CLASS 1 or 2 BLUETOOTH MODULE	PAGE	3 of 55
CUSTOMER'S CODE PAN13XX Core Specification	PANASONIC'S CODE See Chapter Ordering Information	DATE	08.11.2017

16.1	Footprint PAN131x without antenna	30
16.2	Footprint PAN132x with antenna	31
17	Labeling Drawing.....	32
18	Mechanical Requirements.....	32
19	Recommended Foot Pattern	33
19.1	Recommended foot pattern PAN131x without antenna	33
19.2	Recommended foot pattern PAN132x with antenna	34
20	Radiation Pattern.....	35
21	Layout Recommendations with Antenna (PAN132x).....	36
22	Bluetooth LE (LOW ENERGY) PAN1316/26	37
22.1	Network Topology	37
22.2	Module Features	37
22.3	Current consumption for different LE scenarios	37
23	ANT PAN1317/27	38
23.1	Network topology	38
23.2	Module Features	38
23.3	ANT Current consumption.....	39
24	Triple mode (BR/EDR + Bluetooth low energy or ANT) PAN1323	39
24.1	Triple Mode Current consumption.....	39
25	Development of Applications.....	40
25.1	Tools to be needed	40
26	Reliability Tests	41
27	Cautions	42
27.1	Design Notes	42
27.2	Installation Notes	42
27.3	Usage Conditions Notes	42
27.4	Storage Notes	43
27.5	Safety Cautions.....	43
27.6	Other cautions.....	44
27.7	Life Support Policy	44
28	Packaging.....	45
28.1	Packaging of PAN131x without antenna	45
28.2	Packaging for PAN132x with antenna.....	48
29	Ordering Information	49
30	RoHS Declaration.....	49
31	Regulatory Information	50
31.1	FCC for US	50
31.2	Industry Canada Certification.....	52
31.3	European Conformity according to RED (2014/53/EU).....	54
31.4	Japanese Radio Law and Japanese Telecommunications Business Law Compliance	55
31.5	Korean Certification	55
31.6	Bluetooth SIG Statement	55

CLASSIFICATION	PRODUCT SPECIFICATION	No. DS-13xx-2400-102	REV. 5.1
SUBJECT	CLASS 1 or 2 BLUETOOTH MODULE	PAGE	4 of 55
CUSTOMER'S CODE PAN13XX Core Specification	PANASONIC'S CODE See Chapter Ordering Information	DATE	08.11.2017

1 ABOUT THIS DOCUMENT

1.1 PURPOSE

This product specification describes Panasonic's HCI, Class 1.5 , TI based, Bluetooth®¹ modules, series number 13xx.

For detailed family overview that includes part numbers see Chapter 29, Ordering Information.

Non-antenna versions will be referred to as PAN131x, versions with antenna will be referred to as PAN132x in this document.

For information and features on Bluetooth Low Energy 4.0 refer to Chapter 21, for information on ANT refer to Chapter 23.

1.2 REVISION HISTORY

Revision	Date	Modification / Remarks
1.00	04.11.2010	1 st internal Release.
1.01	03.12.2010	Included reference to PAN1325 Application Note. AN-1325-2420-111.pdf.
1.02	10.01.2011	Changed wording in Chapter 31.2 "Industry Canada Certification".
1.03	23.05.2011	Included DOC for PAN1315 series. Included PAN13xx ANT and BLE Addendum Rev1.x.pdf reference. Included Note for IO voltage and MLD_OUT pin.
1.04	02.07.2011	Corrected wording in Chapter 31.3 European Conformity.
1.05	28.10.2011	Including CC2560A silicon PAN1315A HW40 at Chapter 2, Chapter New PAN13x5 and Chapter 0. Deleted ES label in Chapter.
1.06	15.11.2011	Added overview for the core specification and their addendums. Updated front page. Updated Related Documents.
3.00	11.01.2012	Merging PAN13xx documents into this specification and correct some format.
3.10	16.01.2012	Minor mistakes fixed.
3.20	29.05.2012	DoC replaced with revised version.
3.30	11.06.2012	Added triple mode stack Module PAN1323, add PAN1323 to ordering and software information overview, Software Block Diagram added, Bluetooth Inter IC-Sound chapter information added Layout Recommendations with Antenna added, Application Note LGA added
3.31	27.06.2012	Added design information to use low pass filter (chapter 11.1 / 11.9) for better noise suppression when using PCM interface.
3.40	18.07.2012	Re-organize chapter Regulatory Information and added 2 chapters.
3.50	31.10.2012	Changed the Overview in chapter Ordering Information Included -40°C to 85°C Version ENW898xxA2KF. So called K-Version.
3.60	17.05.2013	Changed FCC-ID for models ENW89823xxx and ENW89827xxx.
3.70	31.05.2013	DoC replaced with revised version, updated links.
3.71	15.08.2013	Added component values for low pass filter on PCM interface.
3.80	11.11.2013	Changed CC2567 to CC2564 in chapter ordering information.
3.90	03.12.2013	Included CC2560/4B PAN1325/6B in chapter 2.

¹ Bluetooth is a registered trademark of the Bluetooth Special Interest Group.

CLASSIFICATION	PRODUCT SPECIFICATION	No. DS-13xx-2400-102	REV. 5.1
SUBJECT	CLASS 1 or 2 BLUETOOTH MODULE	PAGE	5 of 55
CUSTOMER'S CODE PAN13XX Core Specification	PANASONIC'S CODE See Chapter Ordering Information	DATE	08.11.2017

Revision	Date	Modification / Remarks
4.00	19.12.2013	Updated chapter European Conformity.
4.10	10.01.2014	Added chapter 20 Radiation Pattern.
4.20	28.02.2014	Changed chapter Key Features according to EN regulations.
4.3	24.09.2014	Added chapter 27.
4.4	06.11.2014	Added DoC.
4.5	29.04.2015	Removed chapter 27 and updated chapter 8 Block Diagram.
4.6	07.05.2015	Removed Taiwan Regulatory chapter.
4.61	19.05.2015	Deleted Chapter 2.1 Software Blockdiagram.
4.7	11.06.2015	Changed the wording in chapter 8 Block Diagram.
4.8	23.09.2015	Added Japanese radio law requirements for labeling.
4.9	09.03.2017	Added CC2564C in the product description. Added new partnumber.
5.0	14.06.2017	Editorial changes. Added RED declaration. Added Korean certification chapter.
5.1	08.11.2017	Removed PAN13x6C Version => moved to separate product specification

1.3 RELATED DOCUMENTS

For an update, please refer to the the respective homepage.

- [1] PAN1323ETU Design-Guide: <http://www.panasonic.com/industrial/includes/pdf/PAN1323ETUDesignGuide.pdf>
- [2] CC2560 Product Bulletin: http://focus.ti.com/pdfs/wtbu/cc2560_slyt377.pdf
- [3] Bluetooth SW for MSP430 is supported by IAR IDE service pack 5.10.6 and later. Use full IAR version edition (not the kick-start version). You can find info on IAR at <http://www.iar.com/website1/1.0.1.0/3/1/> and www.MSP430.com . Note, that there is an option for a 30-day free version of IAR evaluation edition.
- [4] PAN13xx CAD data: <http://www.pedeu.panasonic.de/pdf/174ext.zip>
- [5] To help with the implementation of this reference design, Eagle formatted application and layout files are available on the web at the address below.
- [6] www.panasonic.com/industrial/includes/pdf/PAN1323ETU_Eagle_Ver1_1.zip
- [7] Application Note Land Grid Array: <http://www.pedeu.panasonic.de/pdf/184ext.pdf>

1.4 GENERAL INFORMATION

This document may contain errors. Panasonic reserves the right to make corrections, modifications, enhancements, improvements, and other changes to its literature at any time. Customers should obtain the latest relevant information before placing orders and should verify that such information is current and complete. All products are sold subject to Panasonic's terms and conditions of sale supplied at the time of order acknowledgment.

CLASSIFICATION	PRODUCT SPECIFICATION	No. DS-13xx-2400-102	REV. 5.1
SUBJECT	CLASS 1 or 2 BLUETOOTH MODULE	PAGE	6 of 55
CUSTOMER'S CODE PAN13XX Core Specification	PANASONIC'S CODE See Chapter Ordering Information	DATE	08.11.2017

Engineering Samples (ES)

If Engineering Samples are delivered to the customer, these samples have the status "Engineering Samples". This means that the design of this product is not yet concluded. Engineering Samples may be partially or fully functional, and they may differ from the published Product Specification.

Engineering Samples are not qualified and they are not to be used for reliability testing or series production.

Disclaimer

The customer acknowledges that samples may deviate from the Product Specification and may bear defects due to their status of development and the lack of qualification mentioned above.

Panasonic rejects any liability or product warranty for Engineering Samples. In particular, Panasonic disclaims liability for damages caused by:

- The use of the Engineering Sample other than for evaluation purposes, particularly the installation or integration in another product to be sold by the customer,
- Deviation or lapse in function of the Engineering Sample,
- Improper use of the Engineering Sample.

Panasonic Industrial Devices Europe GmbH disclaims any liability for consequential and incidental damages. In case of any queries regarding the Engineering Samples, please contact your local sales partner or the related product manager.

1.5 CONTACT US

Please contact your local Panasonic Sales office for details on additional product options and services:

For Panasonic Sales assistance in the **EU**, visit

<https://eu.industrial.panasonic.com/about-us/contact-us>

Email: wireless@eu.panasonic.com

For Panasonic Sales assistance in **North America**, visit the Panasonic Sales & Support Tool to find assistance near you at

<https://na.industrial.panasonic.com/distributors>

Please visit the **Panasonic Wireless Technical Forum** to submit a question at

<https://forum.na.industrial.panasonic.com>

Please refer to the Panasonic Wireless Connectivity website for further information on our products and related documents:

For complete Panasonic product details in the **EU**, visit

<http://pideu.panasonic.de/products/wireless-modules.html>

For complete Panasonic product details in **North America**, visit

<http://www.panasonic.com/rfmodules>

CLASSIFICATION	PRODUCT SPECIFICATION	No. DS-13xx-2400-102	REV. 5.1
SUBJECT	CLASS 1 or 2 BLUETOOTH MODULE	PAGE	7 of 55
CUSTOMER'S CODE PAN13XX Core Specification	PANASONIC'S CODE See Chapter Ordering Information	DATE	08.11.2017

2 NEW PAN13X5B, PAN13X6B

The PAN13x5B and PAN13x6B Series are based on Texas Instruments CC2560B and CC2564B controller respectively. The PAN13x5B/13x6B Series Modules support assisted mode for the HFP1.6 (WBS) profile or the A2DP profile. The PAN13x6B also supports 10 LE connections (instead of 6 before).

Compatibility:

PAN1315(A/B) and PAN1316(B) are 100% footprint compatible

PAN1325(A/B) and PAN1326(B) are 100% footprint compatible

NOTE: In the following chapters PAN13x5, PAN13x6 naming also considers the A and B version.

As an updated initialization script resident on the application microcontroller is required for modules based on the CC2560A and CC2564A/B, compatibility between the basic, A and B version is dependent on the Bluetooth stack.

BT-Stack solutions provided by software development partners are available for most processors, including linux based host systems.

For detailed family overview that includes part numbers see Chapter 29 Ordering Information.

Contact your stack provider or local Panasonic sales company for currently available Bluetooth Profiles.

CLASSIFICATION	PRODUCT SPECIFICATION	No. DS-13xx-2400-102	REV. 5.1
SUBJECT	CLASS 1 or 2 BLUETOOTH MODULE	PAGE	8 of 55
CUSTOMER'S CODE PAN13XX Core Specification	PANASONIC'S CODE See Chapter Ordering Information	DATE	08.11.2017

3 KEY FEATURES

- Bluetooth specification v2.1 + EDR (Enhanced Data Rate)
- Surface mount type 6.5(9.5 w. Ant.) x 9.0 x 1.8 mm³
- Up to 10 dBm Tx power with transmit power control
- High sensitivity (-93 dBm typ.)
- Texas Instrument's CC256X BlueLink 7.0 inside
- Fast Connection Setup
- Extended SCO Link
- Supports convenient direct connection to battery (2.2-4.8 V), or connect to DC/DC (1.7-1.98 V) for improved power efficiency
- Internal crystal oscillator (26MHz)
- Fully shielded for immunity
- Full Bluetooth data rate up to 2,178kbps asymmetric
- Support for Bluetooth power saving modes (Sniff, Hold)
- Support for very low-power modes (deep sleep and power down)
- Optional support for ultra-low-power mode. Standby with Battery-Backup
- PCM Interface Master / Slave supporting 13 or 16 bit linear, 8 bit μ -law or A-law Codecs and CVSD transcoders on up to 3 SCO channels
- Full 8- to 128-bit encryption
- UART, I²C and PCM Interface
- IO operating voltage = 1.8 V nominal
- Bluetooth profiles such as SPP, A2DP and others are available. Refer to Panasonic's RF module website for a listing of the most current releases.
- Manufactured in conformance with RoHS

4 APPLICATIONS FOR THE MODULE

All Embedded Wireless Applications

- | | |
|--|---|
| <ul style="list-style-type: none"> • Smart Phones • Industrial Control • Medical • Scanners • Wireless Sensors • Low Power | <ul style="list-style-type: none"> • Cable Replacement • Automotive • Access Points • Consumer Electronics • Monitoring and Control • Access Points |
|--|---|

CLASSIFICATION	PRODUCT SPECIFICATION	No. DS-13xx-2400-102	REV. 5.1
SUBJECT	CLASS 1 or 2 BLUETOOTH MODULE	PAGE	9 of 55
CUSTOMER'S CODE PAN13XX Core Specification	PANASONIC'S CODE See Chapter Ordering Information	DATE	08.11.2017

5 DESCRIPTION FOR THE MODULE

The PAN1315 and PAN1315A are short-range, Class 1 or 2, HCI modules for implementing Bluetooth functionality into various electronic devices. A block diagram can be found in Chapter 8.

Communication between the module and the host controller is carried out via UART.

New designs can be completed quickly by mating the PAN13xx series modules with Texas Instruments' MSP430BT5190 that contains Mindtree's EtherMind Bluetooth Protocol Stack and serial port profile, additional computing power can be achieved by choosing TI's Stellaris ARM7 controller that includes StoneStreet One's A2DP profile. Other BT profiles are available on custom development basis.

Additional controllers are also supported by the PAN13xx series by using a TI/Panasonic software development partner to port the Bluetooth stack and profiles. Mindtree's Software Development Kit (SDK) is available on TI's website -- www.ti.com/connectivity.com

CLASSIFICATION	PRODUCT SPECIFICATION	No. DS-13xx-2400-102	REV. 5.1
SUBJECT	CLASS 1 or 2 BLUETOOTH MODULE	PAGE	10 of 55
CUSTOMER'S CODE PAN13XX Core Specification	PANASONIC'S CODE See Chapter Ordering Information	DATE	08.11.2017

6 DETAILED DESCRIPTION

6.1 TERMINAL LAYOUT

6.1.1 Terminal Layout PAN131x without antenna

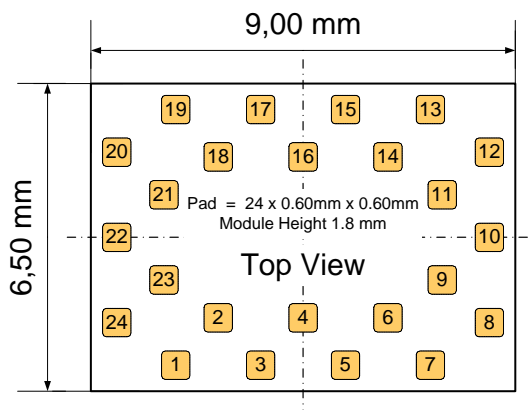

No	Pin Name	Pull at Reset	Def. Dir. ²	I/O Type ³	Description of Options (Common)
1	GND				Connect to Ground
2	TX_DBG	PU	O	2 mA	Logger output
3	HCI_CTS	PU	I	8 mA	HCI UART clear-to-send.
4	HCI_RTS	PU	O	8 mA	HCI UART request-to-send.
5	HCI_RX	PU	I	8 mA	HCI UART data receive
6	HCI_TX	PU	O	8 mA	HCI UART data transmit
7	AUD_FSYNC	PD	IO	4 mA	PCM frame synch. (NC if not used) Fail safe ⁴
8	SLOW_CLK_IN		I		32.768-kHz clock in Fail safe
9	NC		IO		Not connected
10	MLDO_OUT		O		Main LDO output (1.8 V nom.)
11	CL1.5_LDO_IN		I		PA LDO input
12	GND				Connect to Ground
13	RF		IO		Bluetooth RF IO
14	GND				Connect to Ground
15	MLDO_IN		I		Main LDO input
16	nSHUTD	PD	I		Shutdown input (active low).
17	AUD_OUT	PD	O	4 mA	PCM data output. (NC if not used) Fail safe
18	AUD_IN	PD	I	4 mA	PCM data input. (NC if not used) Fail safe
19	AUD_CLK	PD	IO	HY, 4 mA	PCM clock. (NC if not used) Fail safe
20	GND				Connect to Ground
21	NC				EEPROM I ² C SDA (Internal)
22	VDD_IO		PI		I/O power supply 1.8 V Nom
23	NC				EEPROM I ² C SCL (Internal)
24	NC		IO		Not connected

² I = input; O = output; IO = bidirectional; P = power; PU = pulled up; PD = pulled down

³ I/O Type: Digital I/O cells. HY = input hysteresis, current = typ. output current

⁴ No signals are allowed on the IO pins if no VDD_IO (Pin 22) power supplied, except pin 7, 8, 17-19.

CLASSIFICATION	PRODUCT SPECIFICATION	No. DS-13xx-2400-102	REV. 5.1
SUBJECT	CLASS 1 or 2 BLUETOOTH MODULE	PAGE	11 of 55
CUSTOMER'S CODE PAN13XX Core Specification	PANASONIC'S CODE See Chapter Ordering Information	DATE	08.11.2017

6.1.2 Terminal Layout PAN132x with antenna

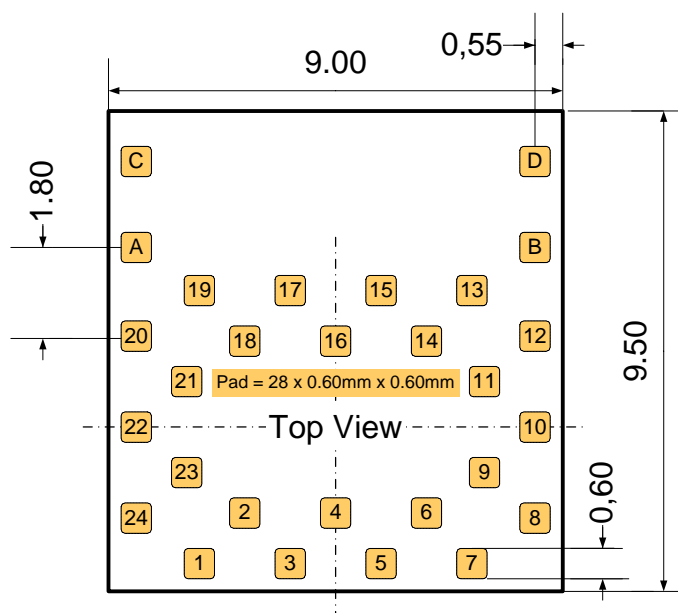

No	Pin Name	Pull at Reset	Def. Dir. ⁵	I/O Type ⁶	Description of Options (Common)
A	GND				Connect to Ground
B	GND				Connect to Ground
C	GND				Connect to Ground
D	GND				Connect to Ground

No 1-24 see above in Chapter 6.1.1. Except PIN 13 is not connected. For RF conducted measurements, either use the PAN1323ETU or de-solder the antenna and solder an antenna connector to the hot pin.

6.2 PIN DESCRIPTION

Pin Name	No	ESD ⁷ (V)	Pull at Reset	Def. Dir. ⁸	I/O Type ⁹	Description of Options
Bluetooth IO SIGNALS						
HCI_RX	5	750	PU	I	8 mA	HCI UART data receive

⁵ I = input; O = output; IO = bidirectional; P = power; PU = pulled up; PD = pulled down

⁶ I/O Type: Digital I/O cells. HY = input hysteresis, current = typ. output current

⁷ ESD: Human Body Model (HBM). JEDEC 22-A114

⁸ I = input; O = output; IO = bidirectional; P = power; PU = pulled up; PD = pulled down

⁹ I/O Type: Digital I/O cells. HY = input hysteresis, current = typ output current

CLASSIFICATION	PRODUCT SPECIFICATION	No. DS-13xx-2400-102	REV. 5.1
SUBJECT	CLASS 1 or 2 BLUETOOTH MODULE	PAGE	12 of 55
CUSTOMER'S CODE PAN13XX Core Specification	PANASONIC'S CODE See Chapter Ordering Information	DATE	08.11.2017

Pin Name	No	ESD ⁷ (V)	Pull at Reset	Def. Dir. ⁸	I/O Type ⁹	Description of Options
HCI_TX	6	750	PU	O	8 mA	HCI UART data transmit
HCI_RTS	4	750	PU	O	8 mA	HCI UART request-to-send.
HCI_CTS	3	750	PU	I	8 mA	HCI UART clear-to-send.
AUD_FYSNC	7	500	PD	IO	4 mA	PCM frame synch (NC if not used) Fail safe
AUD_CLK	19	500	PD	IO	HY, 4 mS	PCM clock (NC if not used) Fail safe
AUD_IN	18	500	PD	I	4 mA	PCM data input (NC if not used) Fail safe
AUD_OUT	17	500	PD	O	4 mA	PCM data output (NC if not used) Fail safe
TX_DBG	2	1000	PU	O	2 mA	Logger output OPTION: nTX_DBG – logger out (low = 1)
CLOCK SIGNALS						
SLOW_CLK_IN	8	1000		I		32.768-kHz clock in Fail safe
Bluetooth ANALOG SIGNALS						
RF	13	1000		IO		Bluetooth RF IO (not connected with antenna)
nSHUTD	16	1000	PD	I		Shutdown input (active low).
Bluetooth POWER AND GND SIGNALS						
VDD_IO	22	1000		PI		I/O power supply 1.8 V Nom
MLDO_IN	15	1000		I		Main LDO input Connect directly to battery or to a pre-regulated 1.8-V supply
MLDO_OUT	10	1000		O		Main LDO output (1.8 V nom.) Can not be used as 1.8V supply due to internal connection to the RF part.
CL1.5_LDO_IN	11	1000		I		PA LDO input Connect directly to battery or to a pre-regulated 1.8-V supply
GND	1			P		Connect to Ground
GND	12			P		Connect to Ground
GND	14			P		Connect to Ground
GND	20			P		Connect to Ground
EEPROM IO SIGNALS (EEPROM is optional in PAN13x product line)						
NC	23	1000	PU/PD	I	HY, 4mA	EEPROM I ² C SCL (Internal)
NC	21	1000	PU/PD	IO	HY, 4mA	EEPROM I ² C IRQ (Internal)

Remark:

HCI_CTS is an input signal to the CC256X device:

- When HCI_CTS is low, then CC256X is allowed to send data to Host device.
- When HCI_CTS is high, then CC256X is not allowed to send data to Host device.

6.3 DEVICE POWER SUPPLY

The PAN13XX Bluetooth radio solution is intended to work in devices with a limited power budget such as cellular phones, headsets, hand-held PC's and other battery-operated devices. One of the main differentiators of the PAN13XX is its power management – its ability to draw as little current as possible.

The PAN13XX device requires two kinds of power sources:

1. Main power supply for the Bluetooth - VDD_IN = V_{BAT}
2. Power source for the 1.8 V I/O ring - VDD_IO

The PAN13XX includes several on-chip voltage regulators for increased noise immunity. The PAN13XX can be connected either directly to the battery or to an external 1.8-V DC to DC converter.

CLASSIFICATION	PRODUCT SPECIFICATION	No. DS-13xx-2400-102	REV. 5.1
SUBJECT	CLASS 1 or 2 BLUETOOTH MODULE	PAGE	13 of 55
CUSTOMER'S CODE PAN13XX Core Specification	PANASONIC'S CODE See Chapter Ordering Information	DATE	08.11.2017

There are three ways to supply power:

1. Full- V_{BAT} system (Maximum RF output power, but not optimum system power):

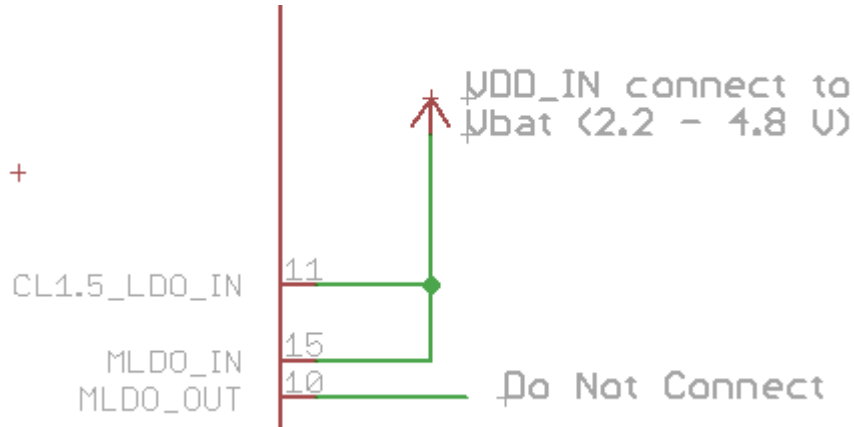

2. Full-DC2DC system (Lower RF output power, but optimum system power):

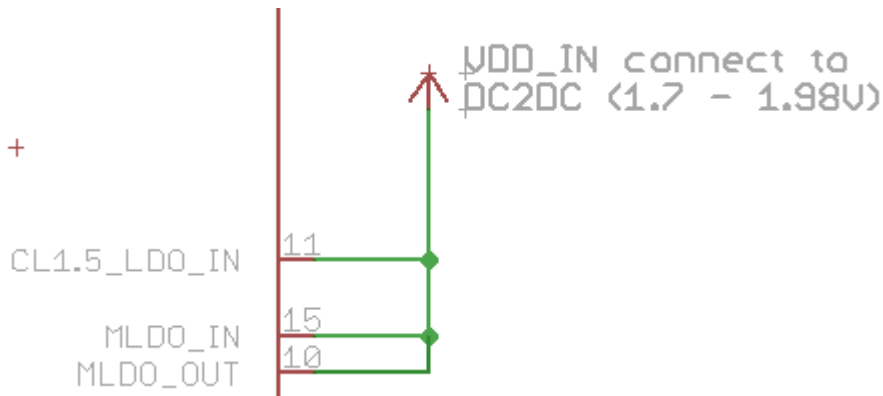

3. Mixed DC2DC- V_{BAT} system (Maximum RF output power and optimum system power, but requires routing of V_{BAT}):

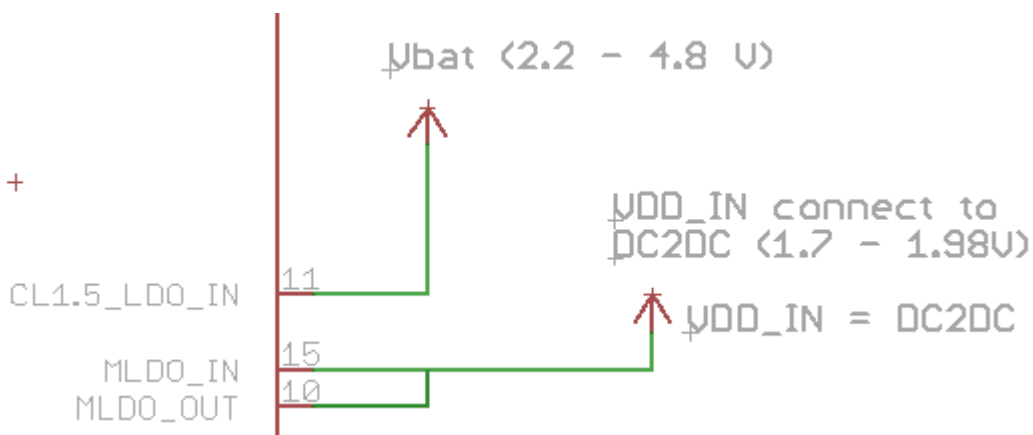

CLASSIFICATION	PRODUCT SPECIFICATION	No. DS-13xx-2400-102	REV. 5.1
SUBJECT	CLASS 1 or 2 BLUETOOTH MODULE	PAGE	14 of 55
CUSTOMER'S CODE PAN13XX Core Specification	PANASONIC'S CODE See Chapter Ordering Information	DATE	08.11.2017

6.4 CLOCK INPUTS

The slow clock is always supplied from an external source. It is connected to the SLOW_CLK_IN pin number 8 and can be a digital signal with peak to peak of 0-1.8 V.

The slow clock's frequency accuracy must be 32.768 kHz \pm 250 ppm for Bluetooth usage (according to the Bluetooth specification).

The Slow Clock 32.768 kHz is mandatory to start the internal controller, otherwise the module does not start up.

7 BLUETOOTH FEATURES

- Support of Bluetooth2.1+EDR (Lisbon Release) up to HCI level.
- Very fast AFH algorithm for both ACL and eSCO.
- Supports typically 4 dBm Class 2 TX power w/o external PA, improving Bluetooth link robustness. Adjusting the host settings, the TX power can be increased to 10 dBm. However it is important, that the national regulations and Bluetooth specification are met.
- Digital Radio Processor (DRP) single-ended 50 ohm.
- Internal temperature detection and compensation ensures minimal variation in the RF performance over temperature.
- Flexible PCM and I2S digital audio/voice interfaces: Full flexibility of data-format (Linear, a-Law, μ -Law), data-width, data order, sampling and slot positioning, master/slave modes, high clock rates up to 15 MHz for slave mode (or 4.096 MHz for Master Mode). Lost packet concealment for improved audio.
- Proprietary low-power scan method for page and inquiry scans, achieves page and inquiry scans at 1/3rd normal power.

CLASSIFICATION	PRODUCT SPECIFICATION	No. DS-13xx-2400-102	REV. 5.1
SUBJECT	CLASS 1 or 2 BLUETOOTH MODULE	PAGE	15 of 55
CUSTOMER'S CODE PAN13XX Core Specification	PANASONIC'S CODE See Chapter Ordering Information	DATE	08.11.2017

8 BLOCK DIAGRAM

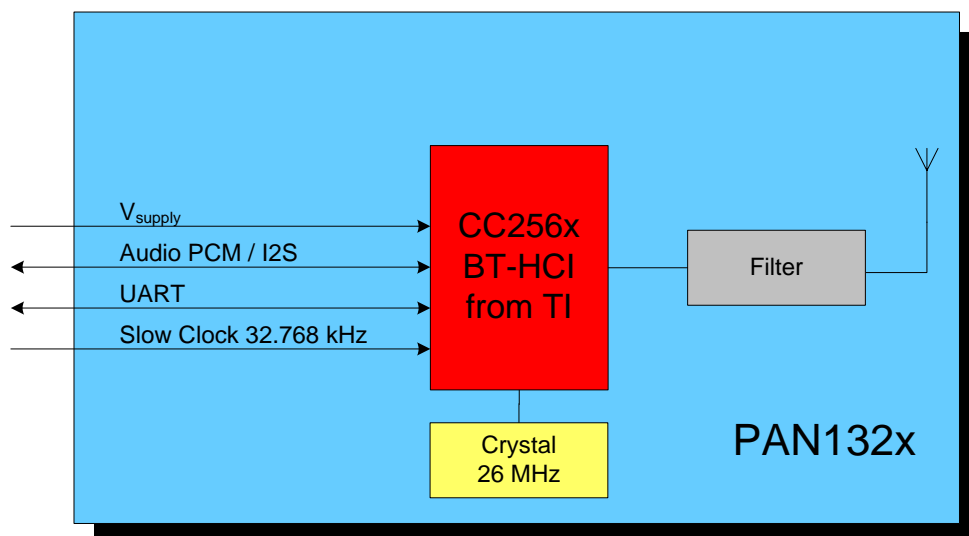
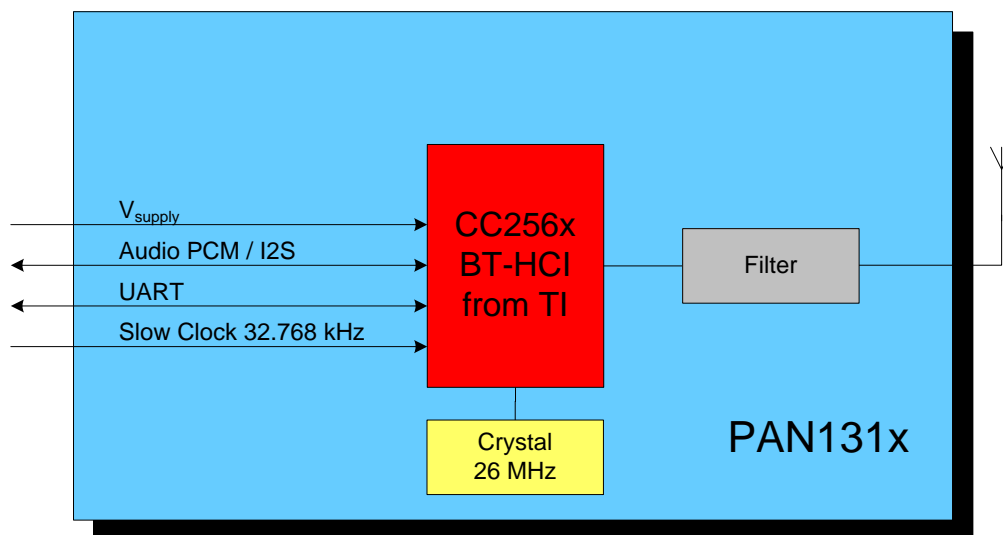

Note: The Slow Clock 32.768 kHz is mandatory, otherwise the module does not start up, refer to Chapter 6.4 for additional information.

Note: The IO are 1.8V driven and might need external level shifter and LDO. The MLDO_OUT PIN can not be used as reference due to RF internal connection.

The total capacity will not exceed 2.8uF and the total inductance will not exceed 0nH. There are no voltage multiplying or voltage boosting circuits.

CLASSIFICATION	PRODUCT SPECIFICATION	No. DS-13xx-2400-102	REV. 5.1
SUBJECT	CLASS 1 or 2 BLUETOOTH MODULE	PAGE	16 of 55
CUSTOMER'S CODE PAN13XX Core Specification	PANASONIC'S CODE See Chapter Ordering Information	DATE	08.11.2017

9 TEST CONDITIONS

Measurements shall be made under room temperature and humidity unless otherwise specified.

10 GENERAL DEVICE REQUIREMENTS AND OPERATION

Temperature	25 ± 10°C
Humidity	40 to 85%RH
SW-Patch	V2.30
Supply Voltage	3.3V

All specifications are over temperature and process, unless indicated otherwise.

10.1 ABSOLUTE MAXIMUM RATINGS

Over operating free-air temperature range (unless otherwise noted).

Note

All parameters are measured as follows unless stated otherwise:

VDD_IN¹⁰ = 3.3 V, VDD_IO = 1.8 V.

No	See ¹¹	Value	Unit
Ratings Over Operating Free-Air Temperature Range			
1	VDD_IN	Supply voltage range	-0.5 to 5.5 V ¹²
2	VDDIO_1.8V		-0.5 to 2.145 V
3	Input voltage to RF (Pin 13)		-0.5 to 2.1 V
4	Operating ambient temperature range		-40 to 85 ¹³ °C
5	Storage temperature range		-40 to 125 °C
6	Bluetooth RF inputs (Pin 13)		10 dBm
7	ESD: Human Body Model (HBM). JEDEC 22-A114		500 V

¹⁰ VDD_IN is supplied to MLDO_IN (Pin 15) and CL1.5_LDO_IN (Pin 11), other options are described in Chapter 6.3.

¹¹ Stresses beyond those listed under "absolute maximum ratings" may cause permanent damage to the device. These are stress ratings only and functional operation of the device at these or any other conditions beyond those indicated under "recommended operating conditions" is not implied. Exposure to absolute-maximum-rated conditions for extended periods may affect device reliability.

¹² Maximum allowed depends on accumulated time at that voltage: VDD_IN is defined in Reference schematics. When DC2DC supply is used, maximum voltage into MLDO_OUT and LDO_IN = 2.145 V.

¹³ Older generation parts, which are not recommended for new designs, will support a temperature range -20 to 70. See chapter 28, ordering information, for details.

CLASSIFICATION	PRODUCT SPECIFICATION	No. DS-13xx-2400-102	REV. 5.1
SUBJECT	CLASS 1 or 2 BLUETOOTH MODULE	PAGE	17 of 55
CUSTOMER'S CODE PAN13XX Core Specification	PANASONIC'S CODE See Chapter Ordering Information	DATE	08.11.2017

10.2 RECOMMENDED OPERATING CONDITIONS

No	Rating	Condition	Symbol	Min	Max	Unit
1	Power supply voltage ¹⁴		VDD_IN	1.7	4.8	V
2	IO power supply voltage		VDD_IO	1.62	1.92	V
3	High-level input voltage	Default	V _{IH}	0.65 x VDD_IO	VDD_IO	V
4	Low-level input voltage	Default	V _{IL}	0	0.35 x VDD_IO	V
5	IO Input rise/fall times, 10% to 90% ¹⁵		Tr/Tf	1	10	ns
6	Maximum ripple on VDD_IN (Sine wave) for 1.8 V (DC2DC) mode	0 to 0.1 MHz			60	mVp-p
		0.1 to 0.5 MHz			50	
		0.5 to 2.5 MHz			30	
		2.5 to 3.0 MHz			15	
		> 3.0 MHz			5	
7	Voltage dips on VDD_IN (V _{BAT}) (duration = 577 μs to 2.31 ms, period = 4.6 ms)				400	mV
8	Maximum ambient operating temperature ¹⁶				85	°C
9	Minimum ambient operating temperature ¹⁷				-40	□C

10.3 CURRENT CONSUMPTION

No	Characteristics	Min 25°C	Typ 25°C	Max 25°C	Min -40°C	Typ -40°C	Max -40°C	Min +85°C	Typ +85°C	Max +85°C	Unit
1	Current consumption in shutdown mode ¹⁸		1	3						7	μA
2	Current consumption in deep sleep mode ¹⁹		40	105						700	μA

¹⁴ Excluding 1.98 < VDD_IN < 2.2 V range – not allowed.

¹⁵ Asynchronous mode.

¹⁶ The device can be reliably operated for 7 years at T_{ambient} of 85°C, assuming 25% active mode and 75% sleep mode (15,400 cumulative active power-on hours).

Older generation parts, which are not recommended for new designs, will support a temperature range -20 to 70. See chapter 28, ordering information, for details.

¹⁷ The device can be reliably operated for 7 years at T_{ambient} of 85°C, assuming 25% active mode and 75% sleep mode (15,400 cumulative active power-on hours).

Older generation parts, which are not recommended for new designs, will support a temperature range -20 to 70. See chapter 28, ordering information, for details.

¹⁸ Vbat + Vio

CLASSIFICATION	PRODUCT SPECIFICATION	No. DS-13xx-2400-102	REV. 5.1
SUBJECT	CLASS 1 or 2 BLUETOOTH MODULE	PAGE	18 of 55
CUSTOMER'S CODE PAN13XX Core Specification	PANASONIC'S CODE See Chapter Ordering Information	DATE	08.11.2017

No	Characteristics	Min 25°C	Typ 25°C	Max 25°C	Min -40°C	Typ -40°C	Max -40°C	Min +85°C	Typ +85°C	Max +85°C	Unit
3	Total IO current consumption for active mode			1			1			1	mA
4	Current consumption during transmit DH5 full throughput		40								mA

10.4 GENERAL ELECTRICAL CHARACTERISTICS

No	Rating	Condition	Min	Max	Value		
1	High-level output voltage, V_{OH}	at 2/4/8 mA	$0.8 \times V_{DD_IO}$	V_{DD_IO}	V		
		at 0.1 mA	$V_{DD_IO} - 0.2$	V_{DD_IO}	V		
2	Low-level output voltage, V_{OL}	at 2/4/8 mA	0	$0.2 \times V_{DD_IO}$	V		
		at 0.1 mA	0	0.2	V		
3	IO input impedance	Resistance	1		$M\Omega$		
		Capacitance		5	pF		
4	Output rise/fall times, 10% to 90% (Digital pins)	$C_L = 20$ pF		10	ns		
5	IO pull currents	TX_DBG, PCM bus	PU	typ = 6.5	3.5	9.7	μA
			PD	typ = 27	9.5	55	
		All others	PU	typ = 100	100	300	μA
			PD	typ = 100	100	360	

10.5 NSHUT REQUIREMENTS

No	Parameter	Symbol	Min	Max	Unit
1	Operation mode level ²⁰	V_{IH}	1.42	1.98	V
2	Shutdown mode level	V_{IL}	0	0.4	V
3	Minimum time for nSHUT_DOWN low to reset the device		5		ms
4	Rise/fall times	Tr/Tf		20	μs

10.6 EXTERNAL DIGITAL SLOW CLOCK REQUIREMENTS

No	Characteristics	Condition	Symbol	Min	Typ	Max	Unit
1	Input slow clock frequency				32768		Hz
2	Input slow clock accuracy (Initial + temp + aging)	Bluetooth				± 250	Ppm

¹⁹ $V_{bat} + V_{io} + V_{sd}$ (shutdown)

²⁰ Internal pull down retains shut down mode when no external signal is applied to this pin.

CLASSIFICATION	PRODUCT SPECIFICATION	No. DS-13xx-2400-102	REV. 5.1
SUBJECT	CLASS 1 or 2 BLUETOOTH MODULE	PAGE	19 of 55
CUSTOMER'S CODE PAN13XX Core Specification	PANASONIC'S CODE See Chapter Ordering Information	DATE	08.11.2017

No	Characteristics	Condition	Symbol	Min	Typ	Max	Unit
3	Input transition time Tr/Tf – 10% to 90%		Tr/Tf			100	Ns
4	Frequency input duty cycle			15%	50%	85%	
5	Phase noise	at 1 kHz				-125	dBc/Hz
6	Jitter	Integrated over 300 to 15000 Hz				1	Hz
7	Slow clock input voltage limits	Square wave, DC coupled	V _{IH}	0.65 x VDD_IO		VDD_IO	V peak
			V _{IL}	0		0.35 x VDD_IO	
8	Input impedance			1			MΩ
9	Input capacitance					5	pF

11 HOST CONTROLLER INTERFACE

The CC256X incorporates one UART module dedicated to the host controller interface (HCI) transport layer. The HCI interface transports commands, events, ACL, and synchronous data between the Bluetooth device and its host using HCI data packets.

The UART module supports H4 (4-wires) protocol with maximum baud rate of 4 Mbps for all fast clock frequencies.

After power up the baud rate is set for 115.2 kbps, irrespective of fast clock frequency. The baud rate can thereafter be changed with a vendor specific command. The CC256X responds with a Command Complete Event (still at 115.2 kbps), after which the baud rate change takes place. HCI hardware includes the following features:

- Receiver detection of break, idle, framing, FIFO overflow, and parity error conditions
- Transmitter underflow detection
- CTS/RTS hardware flow control

The interface includes four signals: TXD, RXD, CTS, and RTS. Flow control between the host and the CC256X is byte-wise by hardware.

Flow control is obtained by the following:

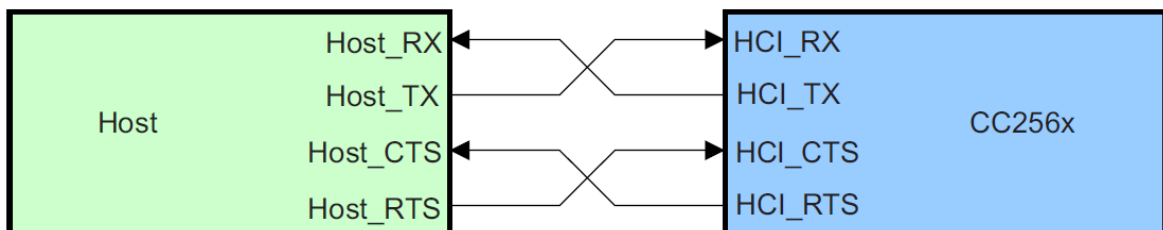

When the UART RX buffer of the CC256X passes the “flow control” threshold, it will set the UART_RTS signal high to stop transmission from the host.

When the UART_CTS signal is set high, the CC256X will stop its transmission on the interface. In case HCI_CTS is set high in the middle of transmitting a byte, the CC256X will finish transmitting the byte and stop the transmission.

CLASSIFICATION	PRODUCT SPECIFICATION	No. DS-13xx-2400-102	REV. 5.1
SUBJECT	CLASS 1 or 2 BLUETOOTH MODULE	PAGE	20 of 55
CUSTOMER'S CODE PAN13XX Core Specification	PANASONIC'S CODE See Chapter Ordering Information	DATE	08.11.2017

12 AUDIO/VOICE CODEC INTERFACE

The codec interface is a fully-dedicated programmable serial port that provides the logic to interface to several kinds of PCM or I2S codec's. PAN13XX supports all voice coding schemes required by Bluetooth specification – Log PCM (A-Law or μ -Law) and Linear (CVSD). In addition, module also supports transparent scheme:

- Two voice channels
- Master / slave modes
- μ -Law, A-Law, Linear, Transparent coding schemes
- Long and short frames
- Different data sizes, order, and positions.
- High rate PCM interface for EDR
- Enlarged interface options to support a wider variety of codecs
- PCM bus sharing

12.1 PCM HARDWARE INTERFACE

The PCM interface is one implementation of the codec interface. It contains the following four lines:

- Clock – configurable direction (input or output)
- Frame Sync – configurable direction (input or output)
- Data In – Input
- Data Out – Output/3-state

The Bluetooth device can be either the master of the interface where it generates the clock and the frame-sync signals, or slave where it receives these two signals. The PCM interface is fully configured by a vendor specific command.

For slave mode, clock input frequencies of up to 16 MHz are supported. At clock rates above 12 MHz, the maximum data burst size is 32 bits. For master mode, the CC256X can generate any clock frequency between 64 kHz and 6 MHz.

When the I2S bus is used in an application, Panasonic recommends adding a low pass filter (series resistor and capacitor to GND) to the bus for better noise suppression. Connecting the host μ Controller/DSP directly with the module's I2S interface is not recommended.

The suggested low pass filter component values are:

470pf
120 ohms

12.2 DATA FORMAT

The data format is fully configurable:

- The data length can be from 8 to 320 bits, in 1-bit increments, when working with two channels, or up to 640 bits when using 1 channel. The Data length can be set independently for each channel.
- The data position within a frame is also configurable in with 1 clock (bit) resolution and can be set independently (relative to the edge of the Frame Sync signal) for each channel.

CLASSIFICATION	PRODUCT SPECIFICATION	No. DS-13xx-2400-102	REV. 5.1
SUBJECT	CLASS 1 or 2 BLUETOOTH MODULE	PAGE	21 of 55
CUSTOMER'S CODE PAN13XX Core Specification	PANASONIC'S CODE See Chapter Ordering Information	DATE	08.11.2017

- The Data_In and Data_Out bit order can be configured independently. For example; Data_In can start with the MSB while Data_Out starts with LSB. Each channel is separately configurable. The inverse bit order (that is, LSB first) is supported only for sample sizes up to 24 bits.
- It is not necessary for the data in and data out size to be the same length.
- The Data_Out line is configured to 'high-Z' output between data words. Data_Out can also be set for permanent high-Z, irrespective of data out. This allows the CC256X to be a bus slave in a multi-slave PCM environment. At power up, Data Out is configured as high-Z.

12.3 FRAME IDLE PERIOD

The codec interface has the capability for frame idle periods, where the PCM clock can “take a break” and become '0' at the end of the PCM frame, after all data has been transferred.

The CC256X supports frame idle periods both as master and slave of the PCM bus.

When CC256X is the master of the interface, the frame idle period is configurable. There are two configurable parameters:

- Clk_Idle_Start – Indicates the number of PCM clock cycles from the beginning of the frame until the beginning of the idle period. After Clk_Idle_Start clock cycles, the clock will become '0'.
- Clk_Idle_End – Indicates the time from the beginning of the frame till the end of the idle period. This time is given in multiples of PCM clock periods.

The delta between Clk_Idle_Start and Clk_Idle_End is the clock idle period.

For example, for PCM clock rate = 1 MHz, frame sync period = 10 kHz, Clk_Idle_Start = 60, Clk_Idle_End = 90.

Between each two frame syncs there are 70 clock cycles (instead of 100). The clock idle period starts 60 clock cycles after the beginning of the frame, and lasts 90 – 60 = 30 clock cycles. This means that the idle period ends 100 – 90 = 10 clock cycles before the end of the frame. The data transmission must end prior to the beginning of the idle period.

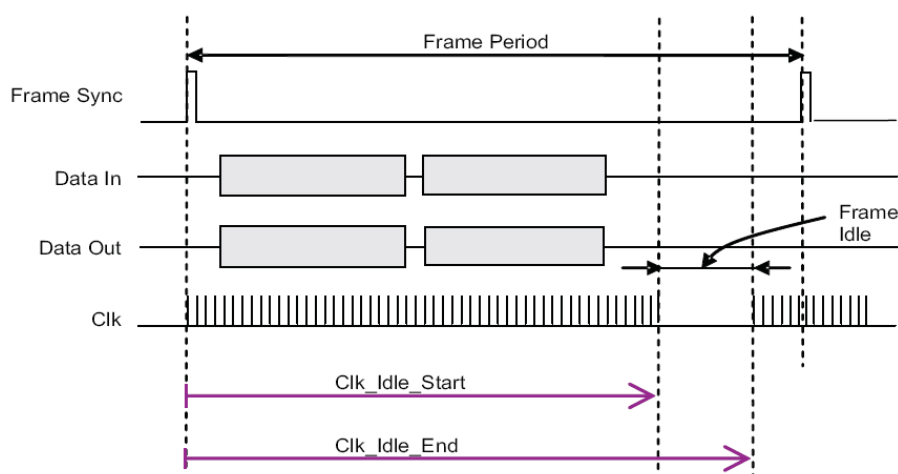

12.4 CLOCK-EDGE OPERATION

The codec interface of the CC256X can work on the rising or the falling edge of the clock. It also has the ability to sample the frame sync and the data at inversed polarity.

This is the operation of a falling-edge-clock type of codec. The codec is the master of the PCM bus. The frame sync signal is updated (by the codec) on the falling clock edge and therefore shall be sampled (by the CC256X) on the next rising clock. The data from the codec is sampled (by the CC256X) on the clock falling edge.

CLASSIFICATION	PRODUCT SPECIFICATION	No. DS-13xx-2400-102	REV. 5.1
SUBJECT	CLASS 1 or 2 BLUETOOTH MODULE	PAGE	22 of 55
CUSTOMER'S CODE PAN13XX Core Specification	PANASONIC'S CODE See Chapter Ordering Information	DATE	08.11.2017

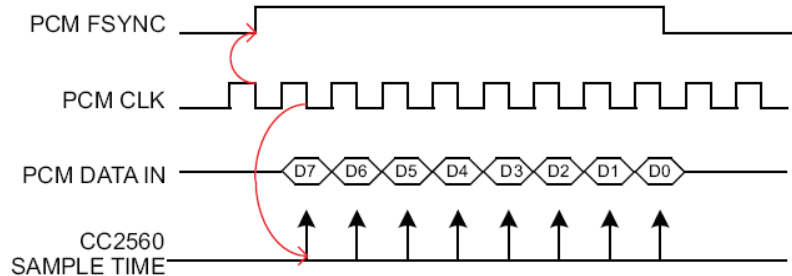

12.5 TWO-CHANNEL PCM BUS EXAMPLE

In below figure, a 2-channel PCM bus is shown where the two channels have different word sizes and arbitrary positions in the bus frame. (FT stands for Frame Timer)

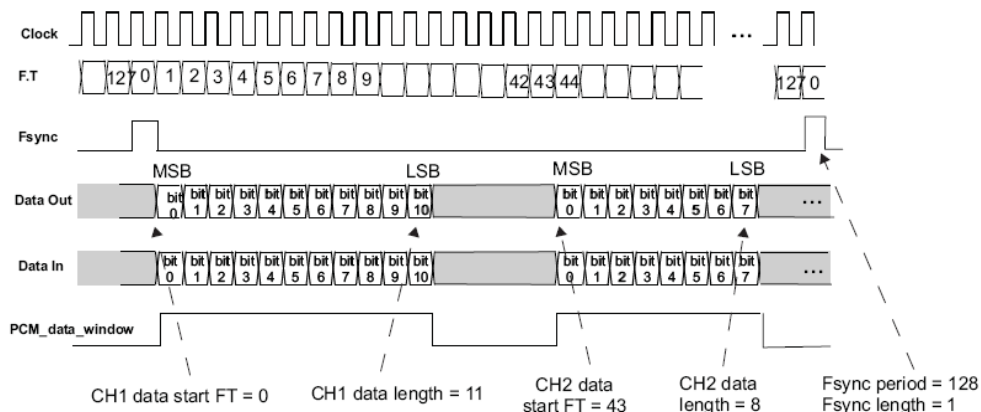

12.6 AUDIO ENCODING

The CC256X codec interface can use one of four audio-coding patterns:

- A-Law (8-bit)
- μ -Law (8-bit)
- Linear (8- or 16-bit)

12.7 IMPROVED ALGORITHM FOR LOST PACKETS

The CC256X features an improved algorithm for improving voice quality when received voice data packets are lost. There are two options:

- Repeat the last sample – possible only for sample sizes up to 24 bits. For sample sizes >24 bits, the last byte is repeated.
- Repeat a configurable sample of 8 to 24 bits (depends on the real sample size), in order to simulate silence (or anything else) in the PCM bus. The configured sample will be written in a specific register for each channel.

The choice between those two options is configurable separately for each channel.

CLASSIFICATION	PRODUCT SPECIFICATION	No. DS-13xx-2400-102	REV. 5.1
SUBJECT	CLASS 1 or 2 BLUETOOTH MODULE	PAGE	23 of 55
CUSTOMER'S CODE PAN13XX Core Specification	PANASONIC'S CODE See Chapter Ordering Information	DATE	08.11.2017

12.8 BLUETOOTH/PCM CLOCK MISMATCH HANDLING

In Bluetooth RX, the CC256X receives RF voice packets and writes these to the codec I/F. If the CC256X receives data faster than the codec I/F output allows, an overflow will occur. In this case, the Bluetooth has two possible behaviour modes: 'allow overflow' and 'don't allow overflow'.

- If overflow is allowed, the Bluetooth will continue receiving data and will overwrite any data not yet sent to the codec.
- If overflow is not allowed, RF voice packets received when buffer is full will be discarded.

12.9 BLUETOOTH INTER-IC SOUND (I2S)

The CC256X can be configured as an Inter-IC Sound (I2S) serial interface to an I2S codec device. In this mode, the CC256X audio codec interface is configured as a bi-directional, full-duplex interface, with two time slots per frame: Time slot 0 is used for the left channel audio data and time slot 1 for the right channel audio data. Each time slot is configurable up to 40 serial clock cycles in length and the frame is configurable up to 80 serial clock cycles in length.

Do not connect the microcontroller/DSP directly to the module's PCM interface, a simple RC low pass filter is recommended to improve noise suppression.

12.10 CURRENT CONSUMPTION FOR DIFFERENT BLUETOOTH SCENARIOS

The following table gives average current consumption for different Bluetooth scenarios.

Conditions: VDD_IN = 3.6 V, 25°C, 26-MHz fast clock, nominal unit, 4 dBm output power.

Mode Description	Master/Slave	Average Current	Unit
Idle current (ARM off)	Master/Slave	2.5	mA
SCO link HV3	Master/Slave	12	mA
eSCO link EV3 64 kbps, no retransmission	Master/Slave	11.5	mA
eSCO link 2-EV3 64 kbps, no retransmission	Master/Slave	8.3	mA
GFSK full throughput: TX = DH1, RX = DH5	Master/Slave	38.5	mA
EDR full throughput: TX = 2-DH1, RX = 2-DH5	Master/Slave	39.2	mA
EDR full throughput: TX = 3-DH1, RX = 3-DH5	Master/Slave	39.2	mA
Sniff, 1 attempt, 1.28 s	Master/Slave	76/100	µA
Page or Inquiry Scan 1.28 s, 11.25 ms	Master/Slave	300	µA
Page (1.28 s) and Inquiry (2.56 s) scans, 11.25 ms	Master/Slave	430	µA
Low power scan, 1.28-s interval, quiet environment	Master/Slave	135	µA

CLASSIFICATION	PRODUCT SPECIFICATION	No. DS-13xx-2400-102	REV. 5.1
SUBJECT	CLASS 1 or 2 BLUETOOTH MODULE	PAGE	24 of 55
CUSTOMER'S CODE PAN13XX Core Specification	PANASONIC'S CODE See Chapter Ordering Information	DATE	08.11.2017

13 BLUETOOTH RF PERFORMANCE

No	Characteristics	Typ	BT Spec	BT Spec
			Max	Min
			Class1	Class1
1	Average Power Hopping DH5 [dBm] ^{22, 23}	7.2	20	4
2	Average Power: Ch0 [dBm] ^{22, 23}	7.5	20	4
3	Peak Power: Ch0 [dBm] ^{22, 23}	7.7	23	
4	Average Power: Ch39 [dBm] ^{22, 23}	7.0	20	4
5	Peak Power: Ch39 [dBm] ^{22, 23}	7.2	23	
6	Average Power: Ch78 [dBm] ^{22, 23}	6.7	20	4
7	Peak Power: Ch78 [dBm] ^{22, 23}	7.0	23	
8	Max. Frequency Tolerance: Ch0 [kHz]	-2.6	75	-75
9	Max. Frequency Tolerance: Ch39 [kHz]	-2.2	75	-75
10	Max. Frequency Tolerance: Ch78 [kHz]	-2.1	75	-75
11	Max. Drift: Ch0_DH1 [kHz]	3.6	25	-25
12	Max. Drift: Ch0_DH3 [kHz]	3.7	40	-40
13	Max. Drift: Ch0_DH5 [kHz]	4.0	40	-40
14	Max. Drift Rate: Ch0_DH1 [kHz]	-2.6	20	-20
15	Max. Drift Rate: Ch0_DH3 [kHz]	-3.2	20	-20
16	Max. Drift Rate: Ch0_DH5 [kHz]	-3.3	20	-20
17	Max. Drift: Ch39_DH1 [kHz]	4.0	25	-25
18	Max. Drift: Ch39_DH3 [kHz]	4.3	40	-40
19	Max. Drift: Ch39_DH5 [kHz]	4.3	40	-40
20	Max. Drift Rate: Ch39_DH1 [kHz]	-3.1	20	-20
21	Max. Drift Rate: Ch39_DH3 [kHz]	-3.6	20	-20
22	Max. Drift Rate: Ch39_DH5 [kHz]	-3.7	20	-20
23	Max. Drift: Ch78_DH1 [kHz]	4.1	25	-25
24	Max. Drift: Ch78_DH3 [kHz]	4.5	40	-40
25	Max. Drift: Ch78_DH5 [kHz]	4.4	40	-40
26	Max. Drift Rate: Ch78_DH1 [kHz]	-3.4	20	-20
27	Max. Drift Rate: Ch78_DH3 [kHz]	-3.9	20	-20
28	Max. Drift Rate: Ch78_DH5 [kHz]	-4.1	20	-20
29	Delta F1 Avg: Ch0 [kHz]	159.5	175	140
30	Delta F2 Max.: Ch0 [%]	100.0		99.9
31	Delta F2 Avg/Delta F1 Avg: Ch0	0.9		0.8
32	Delta F1 Avg: Ch39 [kHz]	159.8	175	140
33	Delta F2 Max.: Ch39 [%]	100.0		99.9
34	Delta F2 Avg/Delta F1 Avg: Ch39	0.9		0.8
35	Delta F1 Avg: Ch78 [kHz]	159.1	175	140
36	Delta F2 Max.: Ch78 [%]	100.0		99.9
37	Delta F2 Avg/Delta F1 Avg: Ch78	0.9		0.8
45	Sensitivity	-93.0		-81
46	f(H)-f(L): Ch0 [kHz]	918.4	1000	
47	f(H)-f(L): Ch39 [kHz]	918.3	1000	
48	f(H)-f(L): Ch78 [kHz]	918.2	1000	
49	ACPower -3: Ch3 [dBm]	-51.5	-40	
50	ACPower -2: Ch3 [dBm]	-50.4	-40	

CLASSIFICATION	PRODUCT SPECIFICATION	No. DS-13xx-2400-102	REV. 5.1
SUBJECT	CLASS 1 or 2 BLUETOOTH MODULE	PAGE	25 of 55
CUSTOMER'S CODE PAN13XX Core Specification	PANASONIC'S CODE See Chapter Ordering Information	DATE	08.11.2017

No	Characteristics	Typ	BT Spec	BT Spec
			Max	Min
			Class1	Class1
51	ACPower -1: Ch3 [dBm]	-18.5		
52	ACPower Center: Ch3 [dBm]	8.1	20	4
53	ACPower +1: Ch3 [dBm]	-19.2		
54	ACPower +2: Ch3 [dBm]	-50.7	-40	
55	ACPower +3: Ch3 [dBm]	-53.3	-40	
56	ACPower -3: Ch39 [dBm]	-51.6	-40	
57	ACPower -2: Ch39 [dBm]	-50.7	-40	
58	ACPower -1: Ch39 [dBm]	-19.0		
59	ACPower Center: Ch39 [dBm]	7.7	20	4
60	ACPower +1: Ch39 [dBm]	-19.7		
61	ACPower +2: Ch39 [dBm]	-50.9	-40	
62	ACPower +3: Ch39 [dBm]	-53.2	-40	
63	ACPower -3: Ch75 [dBm]	-51.7	-40	
64	ACPower -2: Ch75 [dBm]	-50.7	-40	
65	ACPower -1: Ch75 [dBm]	-19.2		
66	ACPower Center: Ch75 [dBm]	7.5	20	4
67	ACPower +1: Ch75 [dBm]	-20.0		
68	ACPower +2: Ch75 [dBm]	-51.0	-40	
69	ACPower +3: Ch75 [dBm]	-53.4	-40	
70	omega i 2-DH5: Ch0 [kHz]	-4.7	75	-75
71	omega o + omega i 2-DH5: Ch0 [kHz]	-6.0	75	-75
72	omega o 2-DH5: Ch0 [kHz]	-1.5	10	-10
73	DEVM RMS 2-DH5: Ch0 [%]	0.0	0.2	
74	DEVM Peak 2-DH5: Ch0 [%]	0.1	0.35	
75	DEVM 99% 2-DH5: Ch0 [%]	100.0		99
76	omega i 3-DH5: Ch0 [kHz]	-3.7	75	-75
77	omega o + omega i 3-DH5: Ch0 [kHz]	-5.8	75	-75
78	omega o 3-DH5: Ch0 [kHz]	-2.6	10	-10
79	DEVM RMS 3-DH5: Ch0 [%]	0.0	0.13	
80	DEVM Peak 3-DH5: Ch0 [%]	0.1	0.25	
81	DEVM 99% 3-DH5: Ch0 [%]	100.0		99
82	omega i 2-DH5: Ch39 [kHz]	-4.8	75	-75
83	omega o + omega i 2-DH5: Ch39 [kHz]	-6.1	75	-75
84	omega o 2-DH5: Ch39 [kHz]	-1.4	10	-10
85	DEVM RMS 2-DH5: Ch39 [%]	0.0	0.2	
86	DEVM Peak 2-DH5: Ch39 [%]	0.1	0.35	
87	DEVM 99% 2-DH5: Ch39 [%]	100.0		99
88	omega i 3-DH5: Ch39 [kHz]	-3.8	75	-75
89	omega o + omega i 3-DH5: Ch39 [kHz]	-5.9	75	-75
90	omega o 3-DH5: Ch39 [kHz]	-2.6	10	-10
91	DEVM RMS 3-DH5: Ch39 [%]	0.0	0.13	
92	DEVM Peak 3-DH5: Ch39 [%]	0.1	0.25	
93	DEVM 99% 3-DH5: Ch39 [%]	100.0		99
94	omega i 2-DH5: Ch78 [kHz]	-4.9	75	-75
95	omega o + omega i 2-DH5: Ch78 [kHz]	-6.2	75	-75

CLASSIFICATION	PRODUCT SPECIFICATION	No. DS-13xx-2400-102	REV. 5.1
SUBJECT	CLASS 1 or 2 BLUETOOTH MODULE	PAGE	26 of 55
CUSTOMER'S CODE PAN13XX Core Specification	PANASONIC'S CODE See Chapter Ordering Information	DATE	08.11.2017

No	Characteristics	Typ	BT Spec	BT Spec
			Max	Min
			Class1	Class1
96	omega o 2-DH5: Ch78 [kHz]	-1.4	10	-10
97	DEVM RMS 2-DH5: Ch78 [%]	0.0	0.2	
98	DEVM Peak 2-DH5: Ch78 [%]	0.1	0.35	
99	DEVM 99% 2-DH5: Ch78 [%]	100.0		99
100	omega i 3-DH5: Ch78 [kHz]	-3.8	75	-75
101	omega o + omega i 3-DH5: Ch78 [kHz]	-6.0	75	-75
102	omega o 3-DH5: Ch78 [kHz]	-2.7	10	-10
103	DEVM RMS 3-DH5: Ch78 [%]	0.0	0.13	
104	DEVM Peak 3-DH5: Ch78 [%]	0.1	0.25	
105	DEVM 99% 3-DH5: Ch78 [%]	100.0		99

No	Characteristics	Condition	Min	Typ	Max	BT Spec	Unit
1	Operation frequency range		2402		2480		MHz
2	Channel spacing			1			MHz
3	Input impedance			50			Ω
4	Sensitivity, Dirty Tx on	GFSK, BER = 0.1%		-93.0		-70	dBm
		Pi/4-DQPSK, BER = 0.01%		-92.5		-70	
		8DPSK, BER = 0.01%		-85.5		-70	

No	Characteristics	Condition	Typ	Max	Unit
1	Tx and Rx out-of-band emissions Output signal = 7dBm	30 kHz to 1 GHz ^{21, 22, 23}		-30	dBm
		1 to 12.75 GHz ^{21, 22, 23}		-30	
2	2 nd harmonic	at 7dBm output power ^{21, 22, 23}		-30	dBm
3	3 rd harmonic	at 7dBm output power ^{21, 22, 23}		-30	dBm

The values are measured conducted. Better suppression of the spurious emissions with an antenna can be expected as, antenna frequently have band pass filter characteristics.

²¹ Includes effects of frequency hopping

²² Average according FCC, IC and ETSI requirements. Above +7dBm output power (refer also to 23) the customer has to verify the final product against national regulations.

²³ +7dBm related to power register value 18, according to TI service pack 2.30

CLASSIFICATION	PRODUCT SPECIFICATION	No. DS-13xx-2400-102	REV. 5.1
SUBJECT	CLASS 1 or 2 BLUETOOTH MODULE	PAGE	27 of 55
CUSTOMER'S CODE PAN13XX Core Specification	PANASONIC'S CODE See Chapter Ordering Information	DATE	08.11.2017

14 SOLDERING TEMPERATURE-TIME PROFILE (FOR REFLOW SOLDERING)

14.1 FOR LEADFREE SOLDER

**Our used temp. profile
for reflow soldering**

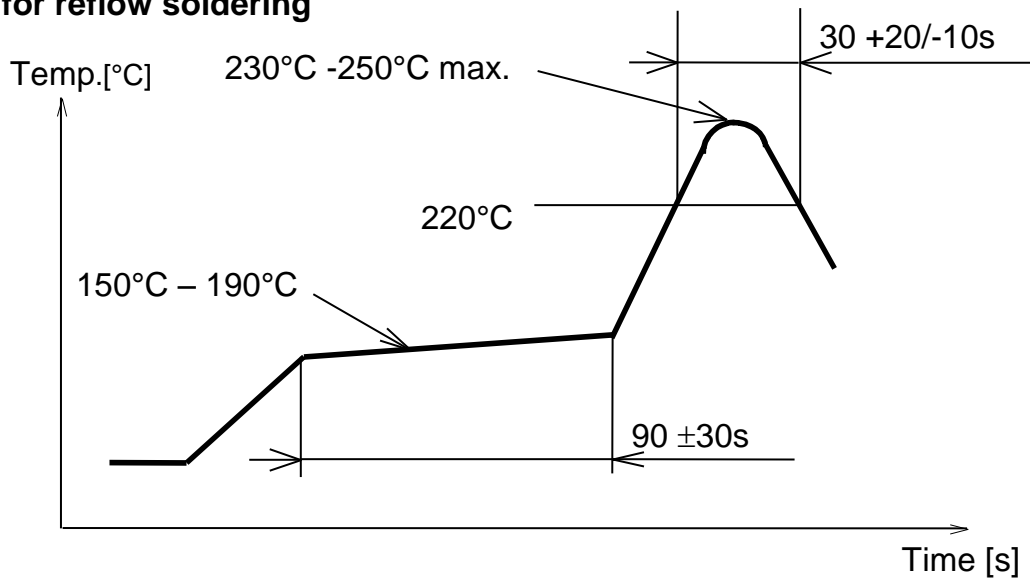

Reflow permissible cycle: 2
Opposite side reflow is prohibited due to module weight.

CLASSIFICATION	PRODUCT SPECIFICATION	No. DS-13xx-2400-102	REV. 5.1
SUBJECT	CLASS 1 or 2 BLUETOOTH MODULE	PAGE	28 of 55
CUSTOMER'S CODE PAN13XX Core Specification	PANASONIC'S CODE See Chapter Ordering Information	DATE	08.11.2017

15 MODULE DIMENSION

15.1 MODULE DIMENSIONS PAN131X WITHOUT ANTENNA

No.	Item	Dimension	Tolerance	Remark
1	Width	6.50	± 0.20	
2	Lenght	9.00	± 0.20	
3	Height	1.80	± 0.20	With case

15.1.1 PAN131X Module Drawing

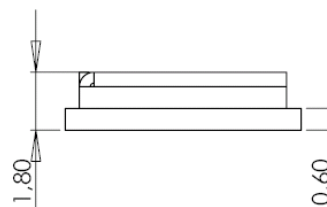
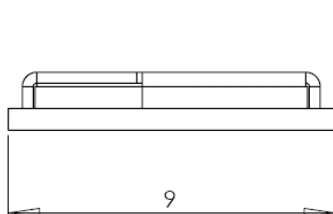
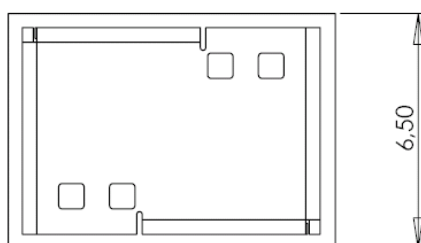
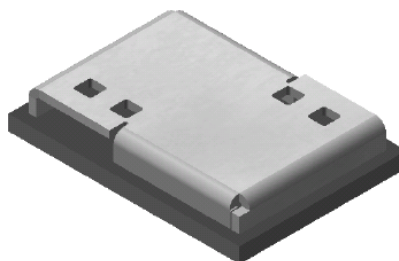

CLASSIFICATION	PRODUCT SPECIFICATION	No. DS-13xx-2400-102	REV. 5.1
SUBJECT	CLASS 1 or 2 BLUETOOTH MODULE	PAGE	29 of 55
CUSTOMER'S CODE PAN13XX Core Specification	PANASONIC'S CODE See Chapter Ordering Information	DATE	08.11.2017

15.2 MODULE DIMENSIONS PAN132X WITH ANTENNA

No.	Item	Dimension	Tolerance	Remark
1	Width	9.50	± 0.20	
2	Lenght	9.00	± 0.20	
3	Height	1.80	± 0.20	With case

15.2.1 PAN132X Module Drawing

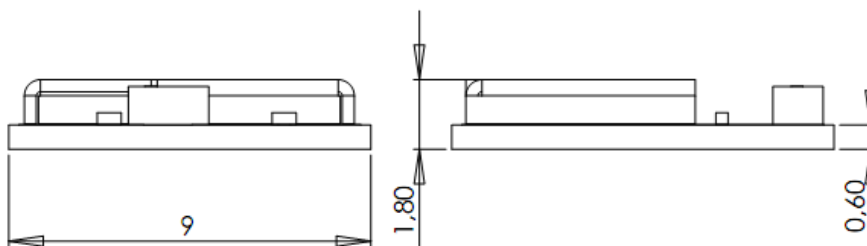
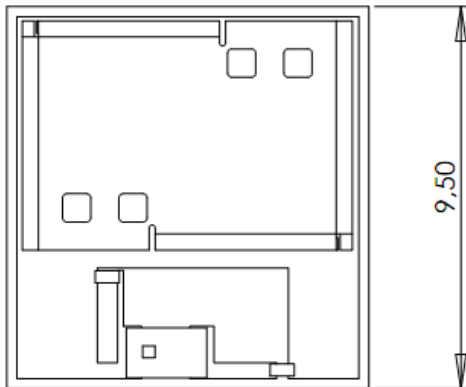
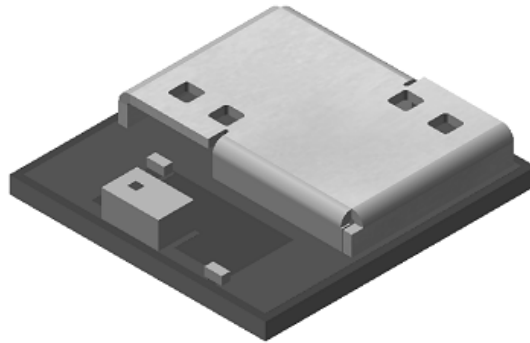

CLASSIFICATION	PRODUCT SPECIFICATION	No. DS-13xx-2400-102	REV. 5.1
SUBJECT	CLASS 1 or 2 BLUETOOTH MODULE	PAGE	30 of 55
CUSTOMER'S CODE PAN13XX Core Specification	PANASONIC'S CODE See Chapter Ordering Information	DATE	08.11.2017

16 FOOTPRINT OF THE MODULE

16.1 FOOTPRINT PAN131X WITHOUT ANTENNA

All dimensions are in millimeters.

The outer dimensions have a tolerance of $\pm 0.2\text{mm}$.

The layout is symmetric to center. The inner pins (2,4,6,9,11,14,16,18,21,23) are shifted to the center by 1mm.

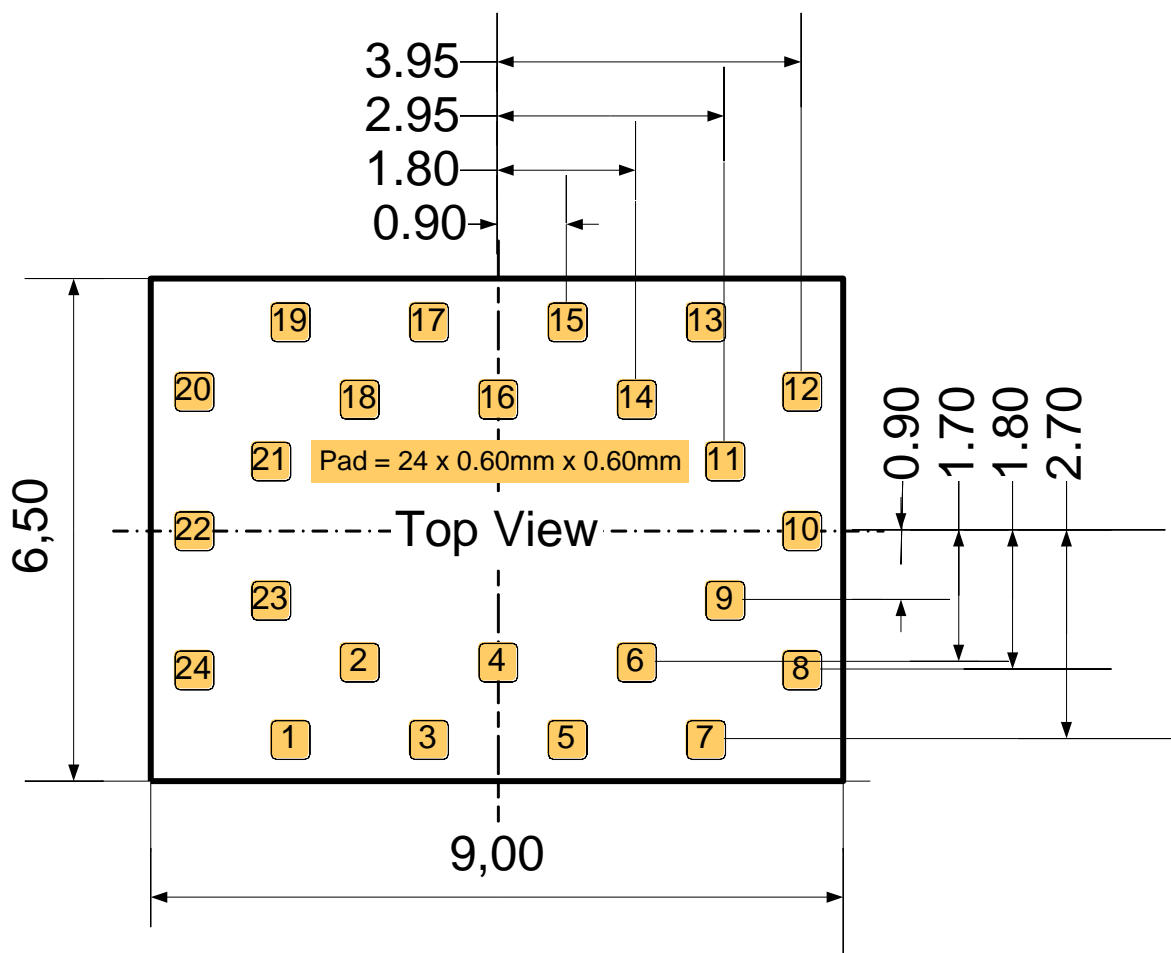

CLASSIFICATION	PRODUCT SPECIFICATION	No. DS-13xx-2400-102	REV. 5.1
SUBJECT	CLASS 1 or 2 BLUETOOTH MODULE	PAGE	31 of 55
CUSTOMER'S CODE PAN13XX Core Specification	PANASONIC'S CODE See Chapter Ordering Information	DATE	08.11.2017

16.2 FOOTPRINT PAN132X WITH ANTENNA

All dimensions are in millimeters.

The outer dimensions have a tolerance of $\pm 0.2\text{mm}$.

The layout is symmetric to center. The inner pins (2,4,6,9,11,14,16,18,21,23) are shifted to the center by 1mm.

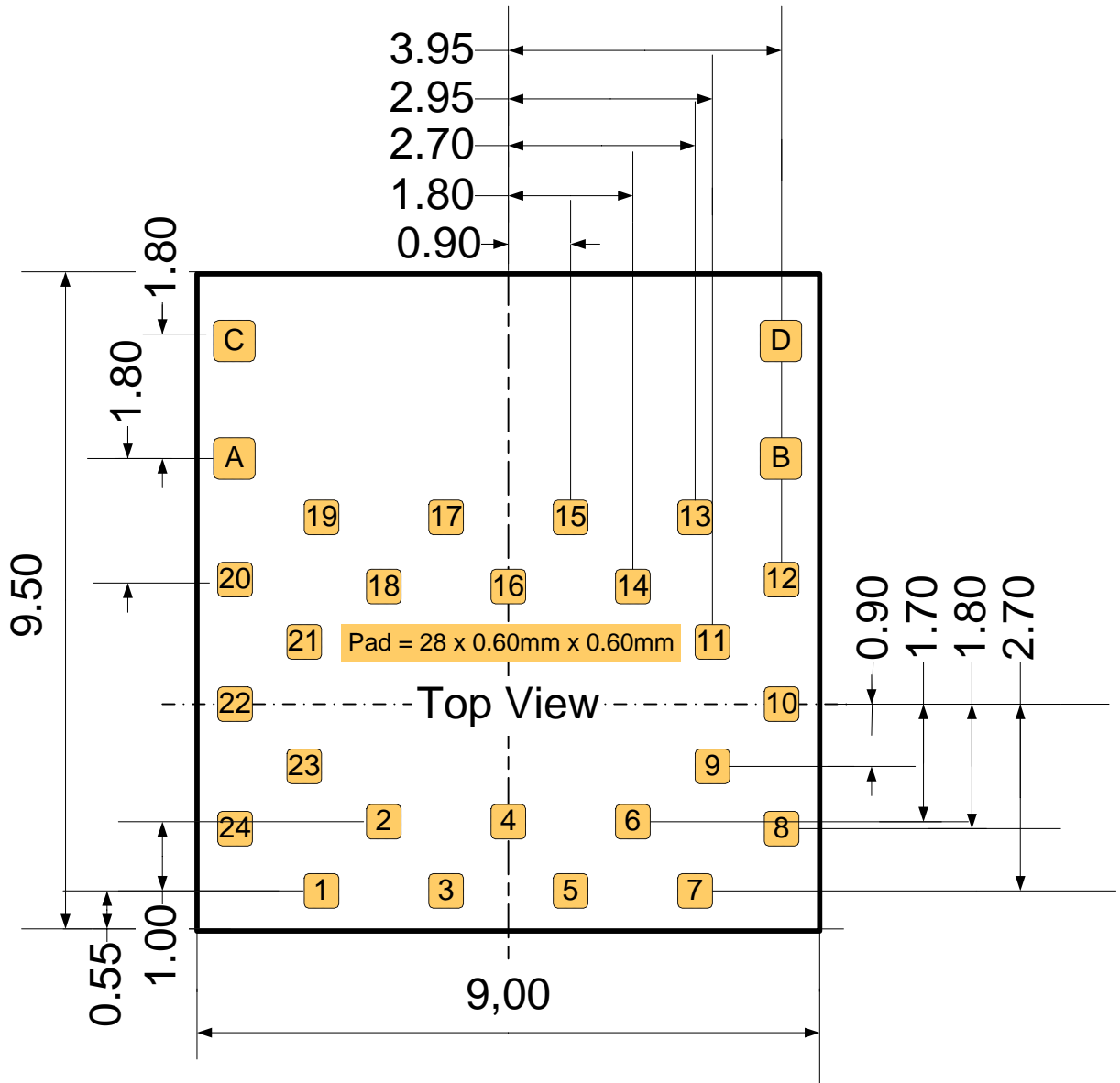

CLASSIFICATION	PRODUCT SPECIFICATION	No. DS-13xx-2400-102	REV. 5.1
SUBJECT	CLASS 1 or 2 BLUETOOTH MODULE	PAGE	32 of 55
CUSTOMER'S CODE PAN13XX Core Specification	PANASONIC'S CODE See Chapter Ordering Information	DATE	08.11.2017

17 LABELING DRAWING

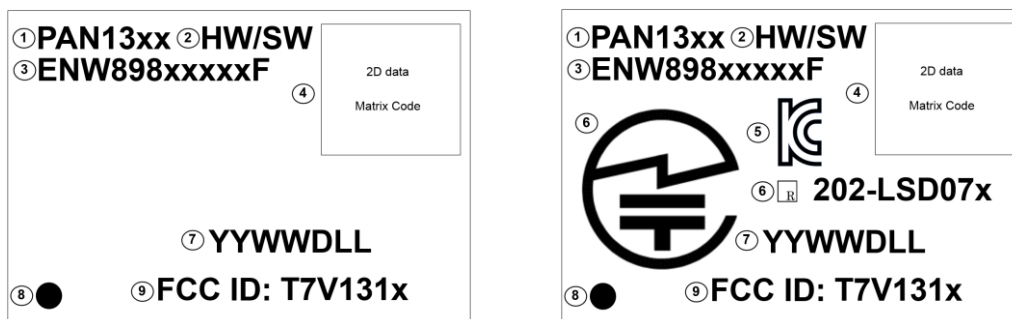

The above pictures show the laser marking on the top case, this is only an example.

- 1: Brand Name
- 2: Hardware Version
- 3: Order Number
- 4: 2D Data Matrix Code
- 5: KCC Logo
- 6: MIC Logo/ID
- 7: Lot code
- 8: PIN1 Marking
- 9: FCC ID

18 MECHANICAL REQUIREMENTS

No.	Item	Limit	Condition
1	Solderability	More than 75% of the soldering area shall be coated by solder	Reflow soldering with recommendable temperature profile
2	Resistance to soldering heat	It shall be satisfied electrical requirements and not be mechanical damage	See Chapter 14.1

CLASSIFICATION	PRODUCT SPECIFICATION	No. DS-13xx-2400-102	REV. 5.1
SUBJECT	CLASS 1 or 2 BLUETOOTH MODULE	PAGE	33 of 55
CUSTOMER'S CODE PAN13XX Core Specification	PANASONIC'S CODE See Chapter Ordering Information	DATE	08.11.2017

19 RECOMMENDED FOOT PATTERN

19.1 RECOMMENDED FOOT PATTERN PAN131X WITHOUT ANTENNA

Dimensions in mm.

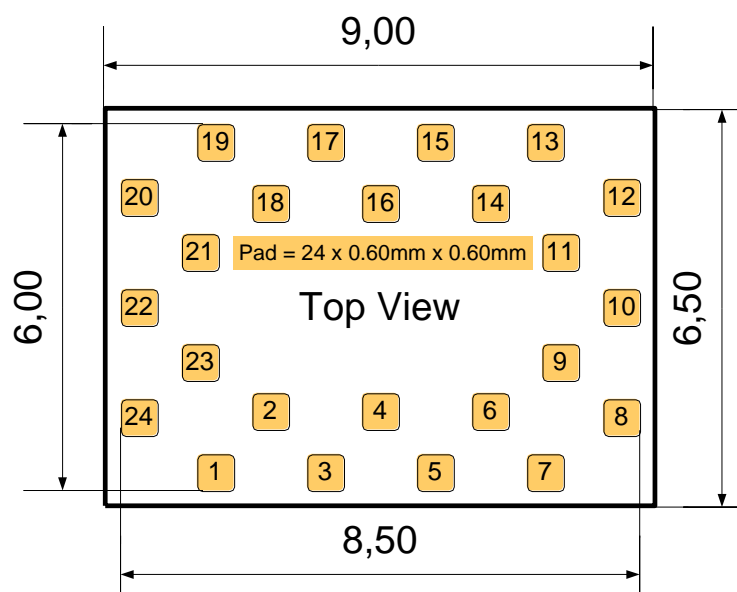

The land pattern dimensions above are meant to serve only as a guide. This information is provided without any legal liability.

For the solder paste screen, use as a first guideline the same foot print as shown in the figure above. Solder paste screen cutouts (with slightly different dimensions) might be optimum depending on your soldering process. For example, the solder paste screen thickness chosen might have an effect. The solder screen thickness depends on your production standard 120µm to 150µm is recommended.

IMPORTANT:

Although the bottom side of PAN131X is fully coated, no copper such as through hole vias, planes or tracks on the board component layer should be located below the PAN131X to avoid creating a short. In cases where a track or through hole via has to be located under the module, it must be kept away from PAN131X bottom pads. The PAN131X multilayer pcb contains an inner RF shielding plane, therefore no pcb shielding plane below the module is needed.

When using an onboard ceramic antenna, place the antenna on the edge of your carrier board (if allowable).

If you have any questions on these points, contact your local Panasonic representative.

Schematics and layouts may be sent to wireless@eu.panasonic.com for final review.

CLASSIFICATION	PRODUCT SPECIFICATION	No. DS-13xx-2400-102	REV. 5.1
SUBJECT	CLASS 1 or 2 BLUETOOTH MODULE	PAGE	34 of 55
CUSTOMER'S CODE PAN13XX Core Specification	PANASONIC'S CODE See Chapter Ordering Information	DATE	08.11.2017

19.2 RECOMMENDED FOOT PATTERN PAN132X WITH ANTENNA

Dimensions in mm.

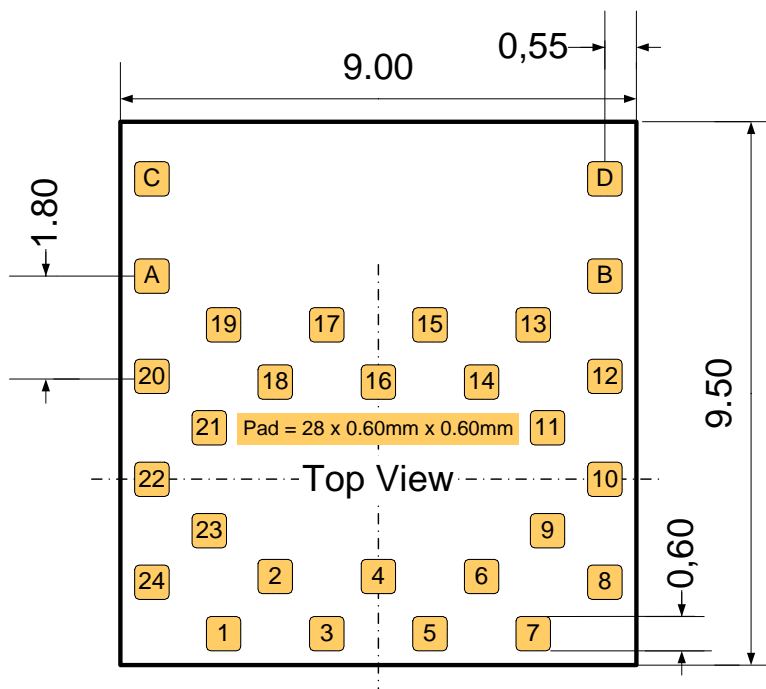

The land pattern dimensions above are meant to serve only as a guide.

For the solder paste screen, use as a first guideline the same foot print as shown in the Figure above. Solder paste screen cutouts (with slightly different dimensions) might be optimum depending on your soldering process. For example, the solder paste screen thickness chosen might have an effect. The solder screen thickness depends on your production standard 120µm to 150µm is recommended.

IMPORTANT: In cases where a track or through hole via has to be located under the module, it must be kept away from PAN132X bottom pads. The PAN132X multilayer pcb contains an inner RF shielding plane, therefore no pcb shielding plane below the module is needed.

If you have any questions on these points, contact your local Panasonic representative.

Schematics and layouts may be sent to wireless@eu.panasonic.com for final review.

CLASSIFICATION	PRODUCT SPECIFICATION	No. DS-13xx-2400-102	REV. 5.1
SUBJECT	CLASS 1 or 2 BLUETOOTH MODULE	PAGE	35 of 55
CUSTOMER'S CODE PAN13XX Core Specification	PANASONIC'S CODE See Chapter Ordering Information	DATE	08.11.2017

20 RADIATION PATTERN

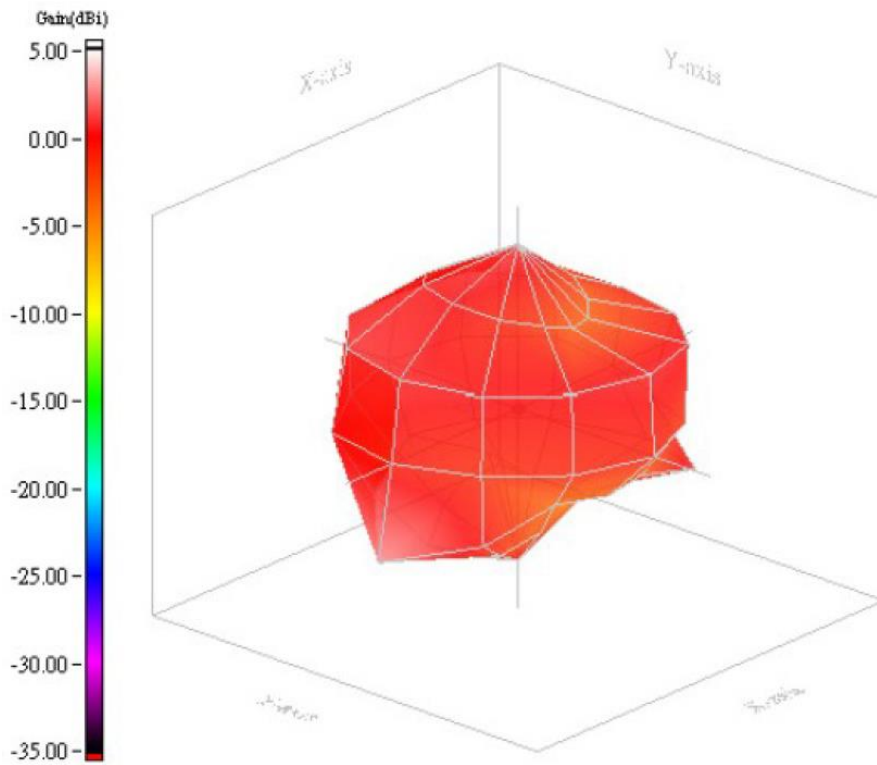

CLASSIFICATION	PRODUCT SPECIFICATION	No. DS-13xx-2400-102	REV. 5.1
SUBJECT	CLASS 1 or 2 BLUETOOTH MODULE	PAGE	36 of 55
CUSTOMER'S CODE PAN13XX Core Specification	PANASONIC'S CODE See Chapter Ordering Information	DATE	08.11.2017

21 LAYOUT RECOMMENDATIONS WITH ANTENNA (PAN132X)

PAN132x WITH ANTENNA PLACEMENT

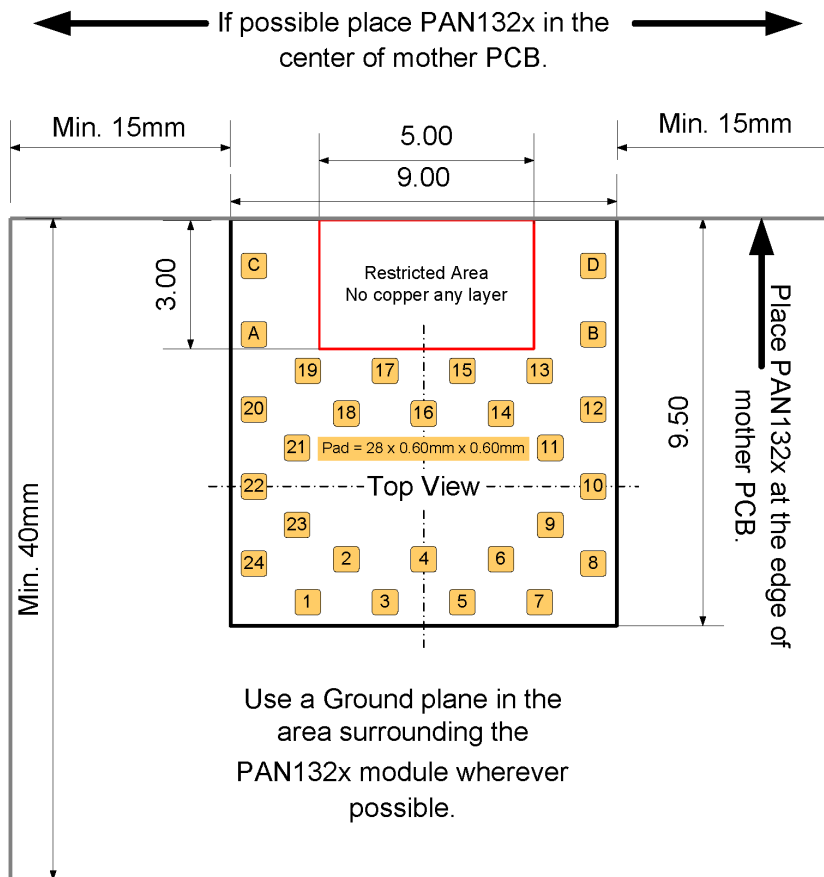

Dimensions are in mm.

CLASSIFICATION	PRODUCT SPECIFICATION	No. DS-13xx-2400-102	REV. 5.1
SUBJECT	CLASS 1 or 2 BLUETOOTH MODULE	PAGE	37 of 55
CUSTOMER'S CODE PAN13XX Core Specification	PANASONIC'S CODE See Chapter Ordering Information	DATE	08.11.2017

22 BLUETOOTH LE (LOW ENERGY) PAN1316/26

22.1 NETWORK TOPOLOGY

Bluetooth Low Energy is designed to reduce power consumption. It can be put into a sleep mode and is only activated for event activities such as sending files to a gateway, PC or mobile phone. Furthermore the maximum power consumption is set to less than 15 mA and the average power consumption is about 1 μ A. The benefits of low energy consumption are short messages and establishing very fast connections (few ms). Using these techniques, energy consumption is reduced to a tenth of a Classic Bluetooth unit. Thus, a small coin cell – such as a CR2032 – is capable of powering a device for up to 10 years of operation.

To be backwards compatible with Classic Bluetooth and to be able to offer an affordable solution for very inexpensive devices, Panasonic Low Energy Bluetooth modules are offered in two versions:

Dual-mode: Bluetooth Low Energy technology combined with Classic Bluetooth functionality on a single module. Dual mode devices act as gateways between these two technologies.

Single Mode: Bluetooth Low Energy technology to optimize power consumption, which is particularly useful for products powered by small batteries. These modules have embedded controllers allowing the module to operate autonomously in low cost applications that lack intelligence.

22.2 MODULE FEATURES

Fully compliant with Bluetooth 4.0:

- Optimized for proximity and sports use
- Supports up to 10 simultaneous connections
- Multiple sniff instances are tightly coupled to minimize power consumption
- Independent buffering allows a large number of multiple connections without affecting BR/EDR performance
- Includes built-in coexistence and prioritization handling for BR/EDR and LE

22.3 CURRENT CONSUMPTION FOR DIFFERENT LE SCENARIOS

Conditions: VDD_IN = 3.6 V, 25°C, 26-MHz fast clock, nominal unit, 10 dBm output power

Mode	Description	Average Current	Unit
Advertising, non-connectable	Advertising in all 3 channels 1.28msec advertising interval 15Bytes advertise Data	104	μ A
Advertising, discoverable	Advertising in all 3 channels 1.28msec advertising interval 15Bytes advertise Data	121	μ A
Scanning	Listening to a single frequency per window 1.28msec scan interval 11.25msec scan window	302	μ A
Connected (master role)	500msec connection interval 0msec Slave connection latency Empty Tx/Rx LL packets	169	μ A

CLASSIFICATION	PRODUCT SPECIFICATION	No. DS-13xx-2400-102	REV. 5.1
SUBJECT	CLASS 1 or 2 BLUETOOTH MODULE	PAGE	38 of 55
CUSTOMER'S CODE PAN13XX Core Specification	PANASONIC'S CODE See Chapter Ordering Information	DATE	08.11.2017

23 ANT PAN1317/27

ANT+ (sometimes ANT + or ANT Plus) is an interoperability function that can be added to the base ANT protocol (a proprietary wireless sensor network technology).

23.1 NETWORK TOPOLOGY

ANT™ is a wireless sensor network protocol operating in the 2.4 GHz spectrum. Designed for ultra-low power, ease of use, efficiency and scalability, ANT supports peer-to-peer, star, tree and fixed mesh topologies. It provides reliable data communications, flexible and adaptive network operation and cross-talk immunity. The ANT protocol stack is compact, requiring minimal microcontroller resources to reduce system costs, lighten the computational burden and improve efficiency. Low-level security is implemented to allow user-defined network security.

PAN1317/1327 provides the first wireless, single-chip solution with dual-mode ANT and Bluetooth connectivity with inclusion of TI's CC2564 device. This solution wirelessly connects 13 million ANT-based devices to the more than 3 billion Bluetooth endpoint devices used by people every day, creating new market opportunities for companies building ANT products and Bluetooth products alike. CC2564 requires 80% less board area than a design with two single-mode solutions (one ANT+, one Bluetooth) and increases the wireless transmission range up to two times the distance of a single-mode ANT+ solution.

23.2 MODULE FEATURES

Fully compliant with ANT protocol:

- ANT solution optimized for fitness, health and consumers use cases
- Supports up to eight simultaneous connections, various network topologies and high-resolution proximity pairing
- Includes built-in coexistence and prioritization handling for BR/EDR and ANT

Features	Benefits
Dual-mode ANT+ and Bluetooth (Bluetooth v2.1 + EDR) on a single chip	<ul style="list-style-type: none"> - Requires 80% less board area than any dual module or device design - Reduces costs associated with incorporating two wireless technologies
Fully validated optimized single antenna solution	<ul style="list-style-type: none"> - Enables simultaneous operation of ANT+ and Bluetooth without the need for two devices or modules - Includes built-in coexistence
Best-in-class Bluetooth and ANT RF performance: <ul style="list-style-type: none"> - +10 dBm Tx power with transmit power control - -93 dBm sensitivity 	<ul style="list-style-type: none"> - Delivers twice the distance between the aggregator and ANT sensor device than competitive single-mode ANT solutions - Enables a robust and high-throughput connection with extended range
Support for: <ul style="list-style-type: none"> - ANT+ ultra low power (master and slave devices) - Bluetooth power saving modes (park, sniff, hold) - Bluetooth ultra low power modes (deep sleep, power down) 	<ul style="list-style-type: none"> - Improves battery life and power efficiency of the finished product
Turnkey solution:	<ul style="list-style-type: none"> - Ease of integration into system allows quick time to market

CLASSIFICATION	PRODUCT SPECIFICATION	No. DS-13xx-2400-102	REV. 5.1
SUBJECT	CLASS 1 or 2 BLUETOOTH MODULE	PAGE	39 of 55
CUSTOMER'S CODE PAN13XX Core Specification	PANASONIC'S CODE See Chapter Ordering Information	DATE	08.11.2017

- Fully integrated module
- Complete development kit with software and documentation
- TI MSP430 hardware and software platform integration (optional)

- Reduces costs and time associated with certification

23.3 ANT CURRENT CONSUMPTION

Mode	Description	Average Current	Unit
Rx message mode	250msec interval	380	μA
Rx message mode	500msec interval	205	μA
Rx message mode	1000msec interval	118	μA

24 TRIPLE MODE (BR/EDR + BLUETOOTH LOW ENERGY OR ANT) PAN1323

The PAN1323 has been engineered to give designers the flexibility to implement Bluetooth Classic (BR/EDR), Bluetooth Low Energy or ANT into an application using a single module, reducing cost and footprint area. Refer to the paragraphs above for complete descriptions on each of the three protocols. The module is fully hardware compatible with the PAN1315, 16, 17, 25, 26 and 27. A highly efficient single RF block serves all three protocols. Protocols access the RF block using time division multiplexing. The application layer determines the priority and timing of the RF block. Customers interested in this unique module are encouraged to contact StoneStreetOne for a Bluetooth SIG certified stack. Note ANT and BLE can not be used simultaneously.

24.1 TRIPLE MODE CURRENT CONSUMPTION

The current consumption of the PAN1323 is a function of the protocol that the module is running at any point in time. Refer to the paragraphs above for details on current consumption for each of the three protocols or software vendor.

CLASSIFICATION	PRODUCT SPECIFICATION	No. DS-13xx-2400-102	REV. 5.1
SUBJECT	CLASS 1 or 2 BLUETOOTH MODULE	PAGE	40 of 55
CUSTOMER'S CODE PAN13XX Core Specification	PANASONIC'S CODE See Chapter Ordering Information	DATE	08.11.2017

25 DEVELOPMENT OF APPLICATIONS

For software versions visit the following links:

www.panasonic.com/rfmodules

http://processors.wiki.ti.com/index.php/CC256x_Forum_Guidelines_and_FAQs

25.1 TOOLS TO BE NEEDED

Tool	Source
TI – MSP-EXP430F5438 – Experimenter Board	MSP-EXP430F5438
TI – MSP-FET430UIF430 – Debugging Interface	MSP-FET430UIF430
PAN1323EMK – Bluetooth Evaluation Module Kit for MSP430	TI PAN1323EMK
	Panasonic PAN1323ETU

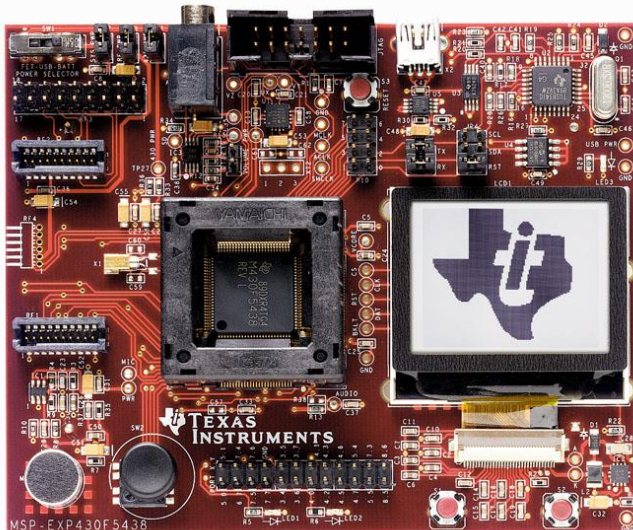

MSP-EXP430F5438
MSP430F5438 Experimenter Board

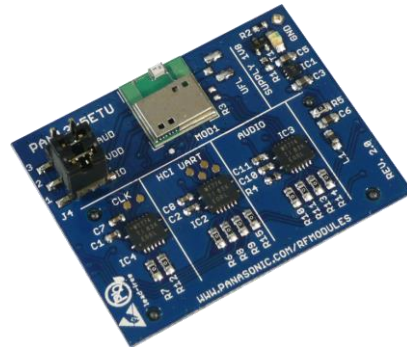

PAN1323ETU

In addition you need the software development environment, e.g. IAR Embedded Workbench, refer to:

http://processors.wiki.ti.com/index.php/CC256x_Bluetooth

http://processors.wiki.ti.com/index.php/CC256x_Forum_Guidelines_and_FAQs

Evaluation kits and modules are available through Panasonic's network of authorized distributors. For any additional information, please visit www.panasonic.com/rfmodules.

CLASSIFICATION	PRODUCT SPECIFICATION	No. DS-13xx-2400-102	REV. 5.1
SUBJECT	CLASS 1 or 2 BLUETOOTH MODULE	PAGE	41 of 55
CUSTOMER'S CODE PAN13XX Core Specification	PANASONIC'S CODE See Chapter Ordering Information	DATE	08.11.2017

26 RELIABILITY TESTS

The measurement should be done after being exposed to room temperature and humidity for 1 hour.

No.	Item	Limit	Condition
1	Vibration test	Electrical parameter should be in specification	a) Freq.:10~50Hz,Amplitude:1.5mm a) 20min. / cycle,1hrs. each of XYZ axis b) Freq.:30~100Hz, 6G b) 20min. / cycle,1hrs. each of XYZ axis
2	Shock test	the same as above	Dropped onto hard wood from height of 50cm for 3 times
3	Heat cycle test	the same as above	-40°C for 30min. and +85°C for 30min.; each temperature 300 cycles
4	Moisture test	the same as above	+60°C, 90% RH, 300h
5	Low temp. test	the same as above	-40°C, 300h
6	High temp. test	the same as above	+85°C, 300h

CLASSIFICATION	PRODUCT SPECIFICATION	No. DS-13xx-2400-102	REV. 5.1
SUBJECT	CLASS 1 or 2 BLUETOOTH MODULE	PAGE	42 of 55
CUSTOMER'S CODE PAN13XX Core Specification	PANASONIC'S CODE See Chapter Ordering Information	DATE	08.11.2017

27 CAUTIONS

Failure to follow the guidelines set forth in this document may result in degrading of the product's functions and damage to the product.

27.1 DESIGN NOTES

- (1) Follow the conditions written in this specification, especially the control signals of this module.
- (2) The supply voltage has to be free of AC ripple voltage (for example from a battery or a low noise regulator output). For noisy supply voltages, provide a decoupling circuit (for example a ferrite in series connection and a bypass capacitor to ground of at least 47uF directly at the module).
- (3) This product should not be mechanically stressed when installed.
- (4) Keep this product away from heat. Heat is the major cause of decreasing the life of these products.
- (5) Avoid assembly and use of the target equipment in conditions where the products' temperature may exceed the maximum tolerance.
- (6) The supply voltage should not be exceedingly high or reversed. It should not carry noise and/or spikes.
- (7) Keep this product away from other high frequency circuits.

27.2 INSTALLATION NOTES

- (1) Reflow soldering is possible twice based on the conditions in Chapter 15. Set up the temperature at the soldering portion of this product according to this reflow profile.
- (2) Carefully position the products so that their heat will not burn into printed circuit boards or affect the other components that are susceptible to heat.
- (3) Carefully locate these products so that their temperatures will not increase due to the effects of heat generated by neighboring components.
- (4) If a vinyl-covered wire comes into contact with the products, then the cover will melt and generate toxic gas, damaging the insulation. Never allow contact between the cover and these products to occur.
- (5) This product should not be mechanically stressed or vibrated when reflowed.
- (6) To repair a board by hand soldering, keep the conditions of this chapter.
- (7) Do not wash this product.
- (8) Refer to the recommended pattern when designing a board.
- (9) Pressing on parts of the metal cover or fastening objects to the metal will cause damage to the unit.

27.3 USAGE CONDITIONS NOTES

- (1) Take measures to protect the unit against static electricity. If pulses or other transient loads (a large load applied in a short time) are applied to the products, check and evaluate their operation before assembly on the final products.
- (2) Do not use dropped products.
- (3) Do not touch, damage or soil the pins.

CLASSIFICATION	PRODUCT SPECIFICATION	No. DS-13xx-2400-102	REV. 5.1
SUBJECT	CLASS 1 or 2 BLUETOOTH MODULE	PAGE	43 of 55
CUSTOMER'S CODE PAN13XX Core Specification	PANASONIC'S CODE See Chapter Ordering Information	DATE	08.11.2017

- (4) Follow the recommended condition ratings about the power supply applied to this product.
- (5) Electrode peeling strength: Do not add pressure of more than 4.9N when soldered on PCB.
- (6) Pressing on parts of the metal cover or fastening objects to the metal cover will cause damage.
- (7) These products are intended for general purpose and standard use in general electronic equipment, such as home appliances, office equipment, information and communication equipment.

27.4 STORAGE NOTES

- (1) The module should not be stressed mechanically during storage.
- (2) Do not store these products in the following conditions or the performance characteristics of the product, such as RF performance will be adversely affected:
 - Storage in salty air or in an environment with a high concentration of corrosive gas, such as Cl₂, H₂S, NH₃, SO₂, or NO_X
 - Storage in direct sunlight
 - Storage in an environment where the temperature may be outside the range of 5°C to 35°C range, or where the humidity may be outside the 45 to 85% range.
 - Storage of the products for more than one year after the date of delivery Storage period: check the adhesive strength of the embossed tape and soldering after 6 months of storage.
- (3) Keep this product away from water, poisonous gas and corrosive gas.
- (4) This product should not be stressed or shocked when transported.
- (5) Follow the specification when stacking packed crates (max. 10).

27.5 SAFETY CAUTIONS

These specifications are intended to preserve the quality assurance of products and individual components.

Before use, check and evaluate the operation when mounted on your products. Abide by these specifications, without deviation when using the products. These products may short-circuit. If electrical shocks, smoke, fire, and/or accidents involving human life are anticipated when a short circuit occurs, then provide the following failsafe functions, as a minimum.

- (1) Ensure the safety of the whole system by installing a protection circuit and a protection device.
- (2) Ensure the safety of the whole system by installing a redundant circuit or another system to prevent a single fault causing an unsafe status.

CLASSIFICATION	PRODUCT SPECIFICATION	No. DS-13xx-2400-102	REV. 5.1
SUBJECT	CLASS 1 or 2 BLUETOOTH MODULE	PAGE	44 of 55
CUSTOMER'S CODE PAN13XX Core Specification	PANASONIC'S CODE See Chapter Ordering Information	DATE	08.11.2017

27.6 OTHER CAUTIONS

- (1) This specification sheet is copyrighted.
- (2) Do not use the products for other purposes than those listed.
- (3) Be sure to provide an appropriate fail-safe function on your product to prevent an additional damage that may be caused by the abnormal function or the failure of the product.
- (4) This product has been manufactured without any ozone chemical controlled under the Montreal Protocol.
- (5) These products are not intended for other uses, other than under the special conditions shown below. Before using these products under such special conditions, check their performance and reliability under the said special conditions carefully to determine whether or not they can be used in such a manner.
 - In liquid, such as water, salt water, oil, alkali, or organic solvent, or in places where liquid may splash.
 - In direct sunlight, outdoors, or in a dusty environment
 - In an environment where condensation occurs.
 - In an environment with a high concentration of harmful gas (e.g. salty air, HCl, Cl₂, SO₂, H₂S, NH₃, and NO_x)
- (6) If an abnormal voltage is applied due to a problem occurring in other components or circuits, replace these products with new products because they may not be able to provide normal performance even if their electronic characteristics and appearances appear satisfactory.
- (7) When you have any question or uncertainty, contact Panasonic.

27.7 LIFE SUPPORT POLICY

This Panasonic product is not designed for use in life support appliances, devices, or systems where malfunction can reasonably be expected to result in a significant personal injury to the user, or as a critical component in any life support device or system whose failure to perform can be reasonably expected to cause the failure of the life support device or system, or to affect its safety or effectiveness. Panasonic customers using or selling these products for use in such applications do so at their own risk and agree to fully indemnify Panasonic for any damages resulting.

CLASSIFICATION	PRODUCT SPECIFICATION	No. DS-13xx-2400-102	REV. 5.1
SUBJECT	CLASS 1 or 2 BLUETOOTH MODULE	PAGE	45 of 55
CUSTOMER'S CODE PAN13XX Core Specification	PANASONIC'S CODE See Chapter Ordering Information	DATE	08.11.2017

28 PACKAGING

28.1 PACKAGING OF PAN131X WITHOUT ANTENNA

28.1.1 Tape Dimension

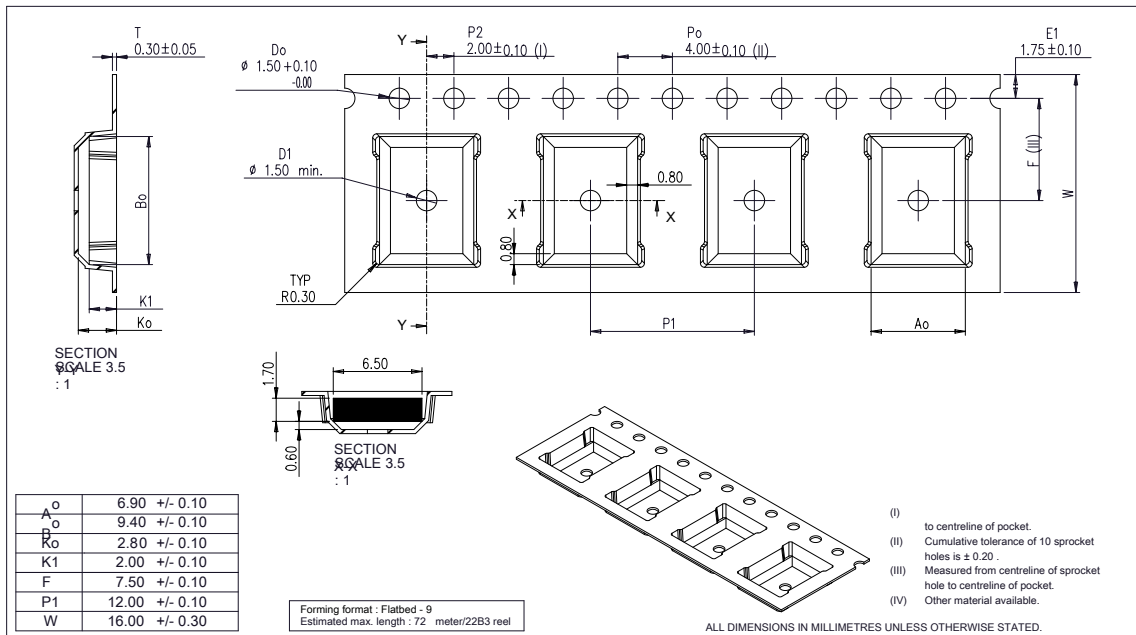

28.1.2 Packing in Tape

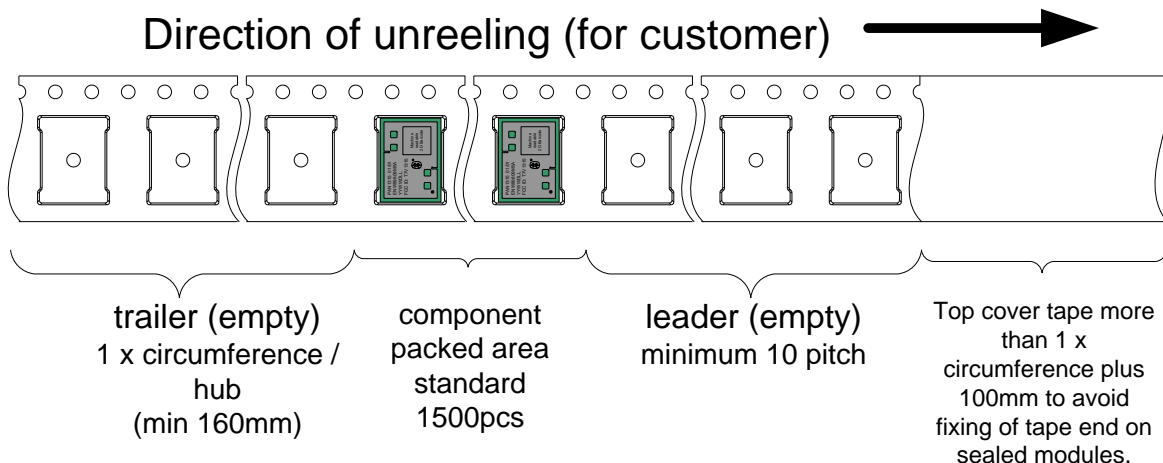

Empty spaces in component packed area shall be less than two per reel and those spaces shall not be consecutive.

Top cover tape shall not be found on reel holes and shall not stick out from reel.

Component direction

CLASSIFICATION	PRODUCT SPECIFICATION	No. DS-13xx-2400-102	REV. 5.1
SUBJECT	CLASS 1 or 2 BLUETOOTH MODULE	PAGE	46 of 55
CUSTOMER'S CODE PAN13XX Core Specification	PANASONIC'S CODE See Chapter Ordering Information	DATE	08.11.2017

28.1.3 Reel Dimension

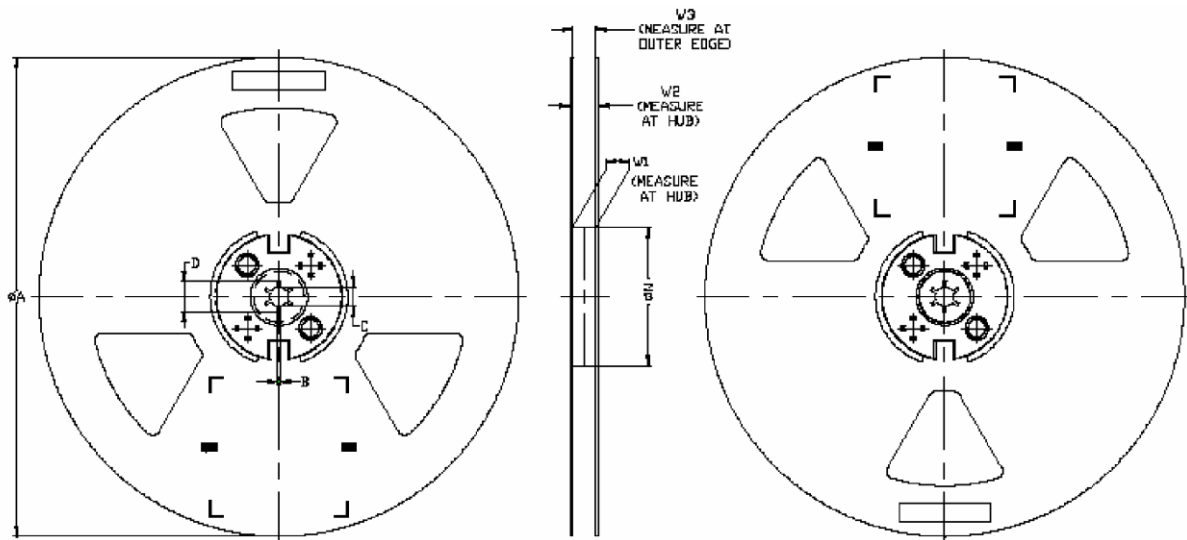
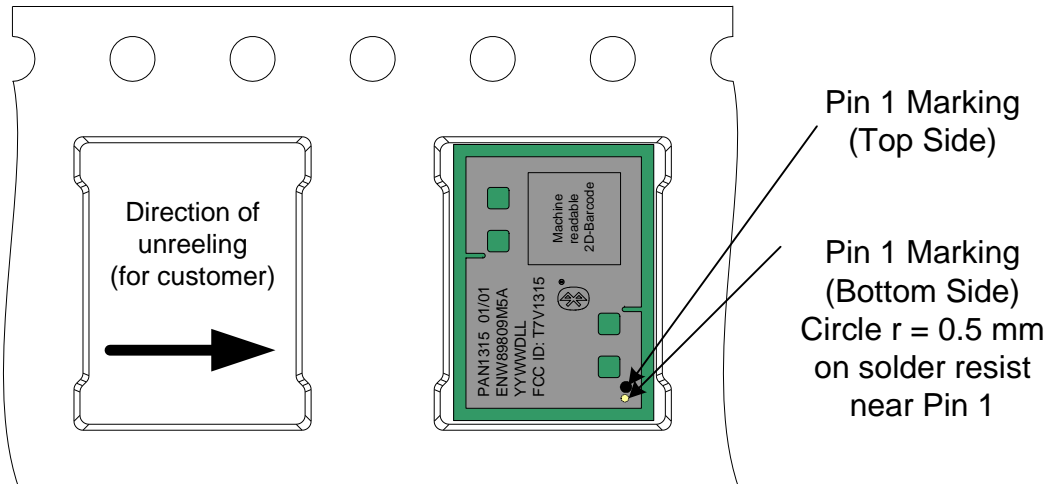

TAPE SIZE	A MAX	B MIN	C	D MIN	N ± 1.0	W1	W2 MAX	W3	Assembly Method
24mm	330.0	1.5	13 ^{+0.5} -0.2	20.2	100.0	25.0 ^{+2.0} -0.0	30.4	24.4 ^{+3.0} -0.5	*Latch

All dimensions in millimeters unless otherwise stated

*Latch (2PC)

CLASSIFICATION	PRODUCT SPECIFICATION	No. DS-13xx-2400-102	REV. 5.1
SUBJECT	CLASS 1 or 2 BLUETOOTH MODULE	PAGE	47 of 55
CUSTOMER'S CODE PAN13XX Core Specification	PANASONIC'S CODE See Chapter Ordering Information	DATE	08.11.2017

28.1.4 Label for Package

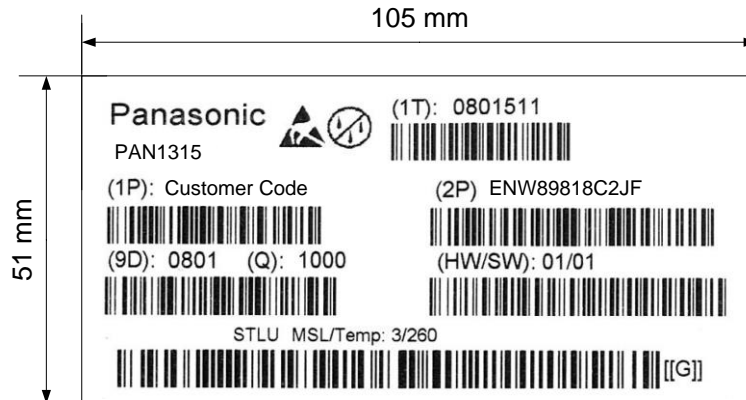

(1T)	Lot code [YYWWDLL] YY year WW normal calendar week D day L line identifier, if more as one L lot identifier per day	Example from above: printed 08 printed 01 printed 5 (Friday) printed 1 printed 1
(1P)	Customer Order Code, if any, otherwise company name will be printed	
(2P)	Panasonic Order Code refer to chapter 29 Ordering Information	
(9D)	Date code as [YYWW]	
(Q)	Quantity [XXXX], variable max. 1500	
(HW/SW)	Hardware /Software Release	

28.1.5 Total Package

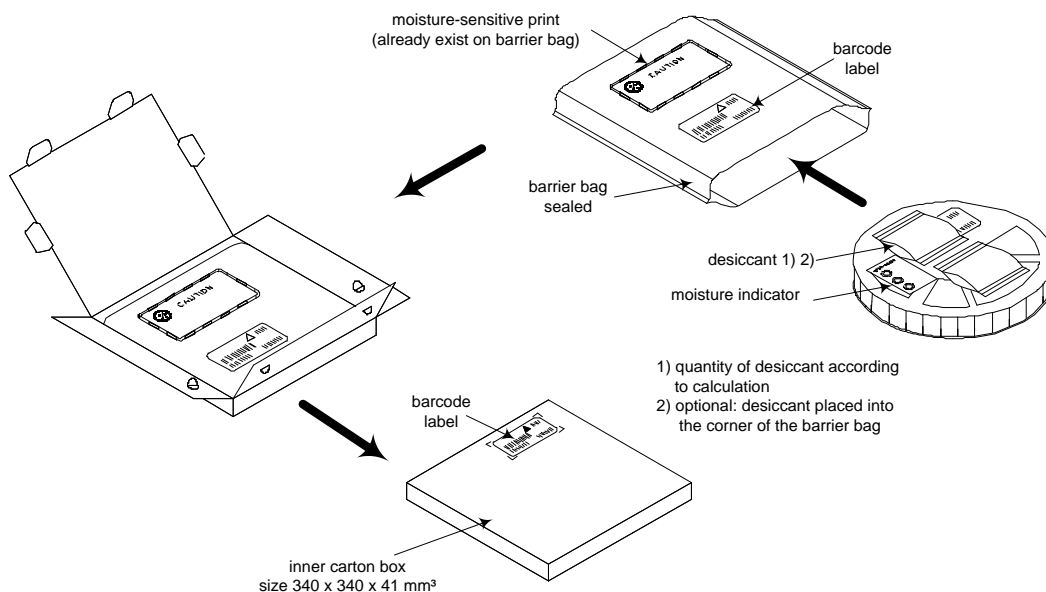

CLASSIFICATION	PRODUCT SPECIFICATION	No. DS-13xx-2400-102	REV. 5.1
SUBJECT	CLASS 1 or 2 BLUETOOTH MODULE	PAGE	48 of 55
CUSTOMER'S CODE PAN13XX Core Specification	PANASONIC'S CODE See Chapter Ordering Information	DATE	08.11.2017

28.2 PACKAGING FOR PAN132X WITH ANTENNA

28.2.1 Tape Dimension

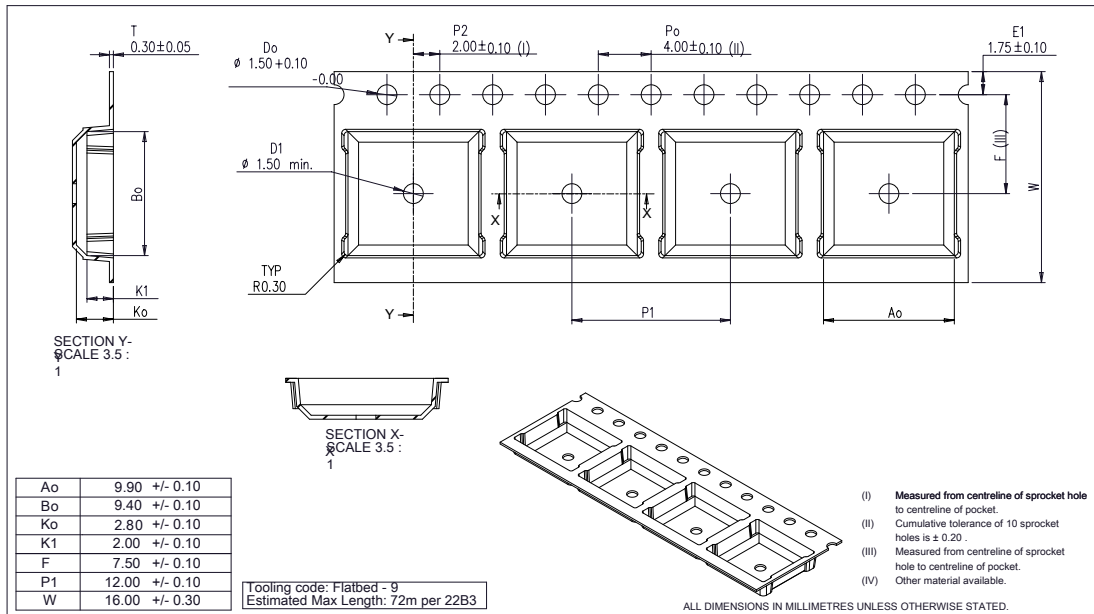

28.2.2 Packing in Tape

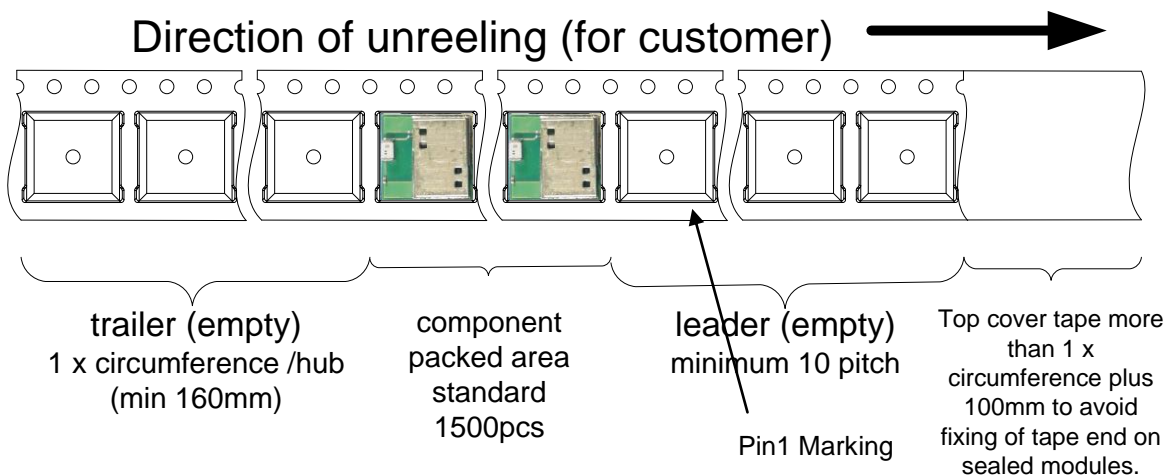

All other packaging information is similar to Chapter 28.1

CLASSIFICATION	PRODUCT SPECIFICATION	No. DS-13xx-2400-102	REV. 5.1
SUBJECT	CLASS 1 or 2 BLUETOOTH MODULE	PAGE	49 of 55
CUSTOMER'S CODE PAN13XX Core Specification	PANASONIC'S CODE See Chapter Ordering Information	DATE	08.11.2017

29 ORDERING INFORMATION

Model	Temp.	Part Number	TI-Device	Remark
PAN1315A	-20°C to +70°C	ENW89829C2JF	CC2560A	NR for new designs
PAN1315A	-40°C to +85°C	ENW89829C2KF	CC2560A	NR for new designs
PAN1315B	-40°C to +85°C	ENW89829C3KF	CC2560B	Recommended for new designs
PAN1316	-20°C to +70°C	ENW89823C2JF	CC2564	NR for new designs
PAN1316	-40°C to +85°C	ENW89823C2KF	CC2564	NR for new designs
PAN1316B	-40°C to +85°C	ENW89823C3KF	CC2564B	Recommended for new designs
PAN1317	-20°C to +70°C	ENW89827C2JF	CC2564	NR for new designs
PAN1317	-40°C to +85°C	ENW89827C2KF	CC2564	NR for new designs
PAN1323	-20°C to +70°C	ENW89842A2JF	CC2564	NR for new designs
PAN1323	-40°C to +85°C	ENW89842A2KF	CC2564	NR for new designs
PAN1325A	-20°C to +70°C	ENW89829A2JF	CC2560A	NR for new designs
PAN1325A	-40°C to +85°C	ENW89829A2KF	CC2560A	NR for new designs
PAN1325B	-40°C to +85°C	ENW89829A3KF	CC2560B	Recommended for new designs
PAN1326	-20°C to +70°C	ENW89823A2JF	CC2564	NR for new designs
PAN1326	-40°C to +85°C	ENW89823A2KF	CC2564	NR for new designs
PAN1326B	-40°C to +85°C	ENW89823A3KF	CC2564B	NR for new designs
PAN1327	-20°C to +70°C	ENW89827A2JF	CC2564	NR for new designs
PAN1327	-40°C to +85°C	ENW89827A2KF	CC2564	NR for new designs

NR: Not recommended

ETU: Easy to use development board

30 ROHS DECLARATION

The latest declaration of environmental compatibility (RoHS and REACH) for supplied products can be found on the Panasonic website in the "Downloads" section of the respective product.

CLASSIFICATION	PRODUCT SPECIFICATION	No. DS-13xx-2400-102	REV. 5.1
SUBJECT	CLASS 1 or 2 BLUETOOTH MODULE	PAGE	50 of 55
CUSTOMER'S CODE PAN13XX Core Specification	PANASONIC'S CODE See Chapter Ordering Information	DATE	08.11.2017

31 REGULATORY INFORMATION

31.1 FCC FOR US

31.1.1 FCC Notice



The devices PAN13xx, for details refer to Chapter 28 in this document, including the antennas, which are listed in Chapter 34.1.5 of this data sheet, complies with Part 15 of the FCC Rules. The device meets the requirements for modular transmitter approval as detailed in FCC public Notice DA00-1407.transmitter. Operation is subject to the following two conditions: (1) This device may not cause harmful interference, and (2) This device must accept any interference received, including interference that may cause undesired operation.

31.1.2 Caution



The FCC requires the user to be notified that any changes or modifications made to this device that are not expressly approved by Panasonic Industrial Devices Europe GmbH may void the user's authority to operate the equipment.

This equipment has been tested and found to comply with the limits for a Class B digital device, pursuant to Part 15 of the FCC Rules. These limits are designed to provide reasonable protection against harmful interference in a residential installation. This equipment generates, uses and can radiate radio frequency energy and, if not installed and used in accordance with the instructions, may cause harmful interference to radio communications. However, there is no guarantee that interference will not occur in a particular installation. If this equipment does cause harmful interference to radio or television reception, which can be determined by turning the equipment off and on, the user is encouraged to try to correct the interference by one or more of the following measures:

- Reorient or relocate the receiving antenna.
- Increase the separation between the equipment and receiver.
- Connect the equipment into an outlet on a circuit different from that to which the receiver is connected.
- Consult the dealer or an experienced radio/TV technician for help

31.1.3 Labeling Requirements



The Original Equipment Manufacturer (OEM) must ensure that FCC labelling requirements are met. This includes a clearly visible label on the outside of the OEM enclosure specifying the appropriate Panasonic FCC identifier for this product as well as the FCC Notice above. The FCC identifiers are:

FCC ID: T7V1315 for PAN1315 and PAN1325

FCC ID: T7V1316 for PAN1316, PAN1317, PAN1326 and PAN1327

These FCC identifiers are valid for all PAN13xx modules, for details, see the Chapter 29. Ordering Information. In any case the end product must be labelled exterior with "Contains FCC ID: T7V1315" (PAN1315, PAN1325) or

"Contains FCC ID: T7V1316" (PAN1316, PAN1317, PAN1326 and PAN1327).

31.1.4 Antenna Warning



For the related part number of PAN13xx refer to Chapter 29. Ordering Information.

These devices are tested with a standard SMA connector and with the antennas listed below. When integrated in the OEMs product, these fixed antennas require installation preventing end-users from replacing them with non-approved antennas. Any antenna not in the following tables must be tested to comply with FCC Section 15.203 for unique antenna connectors and Section

CLASSIFICATION	PRODUCT SPECIFICATION	No. DS-13xx-2400-102	REV. 5.1
SUBJECT	CLASS 1 or 2 BLUETOOTH MODULE	PAGE	51 of 55
CUSTOMER'S CODE PAN13XX Core Specification	PANASONIC'S CODE See Chapter Ordering Information	DATE	08.11.2017

15.247 for emissions. The FCC identifier for this device with the antenna listed below are the same (FCC ID: T7V1315 or T7V1316).

31.1.5 Approved Antenna List (PAN1315, PAN1325)

Note: We are able to qualify your antenna and will add to this list as that process is completed.

Item	Part Number	Manufacturer	Frequency Band	Type	Gain (dBi)
1	2450AT43B100	Johanson Technologies	2.4GHz	Chip-Antenna	+1.3
2	LDA212G3110K	Murata	2.4GHz	Chip-Antenna	+0.9
3	4788930245	Würth Elektronik	2.4GHz	Chip-Antenna	+0.5

31.1.6 Approved Antenna List (PAN1316, PAN1317, PAN1326, PAN1327)

Note: We are able to qualify your antenna and will add to this list as that process is completed.

Item	Part Number	Manufacturer	Frequency Band	Type	Gain (dBi)
1	LDA212G3110K	Murata	2.4GHz	Chip-Antenna	+0.9
2	ANT2012	Yageo	2.4GHz	Chip-Antenna	+0.9

31.1.7 RF Exposure PAN13xx



To comply with FCC RF Exposure requirements, the Original Equipment Manufacturer (OEM) must ensure that the approved antenna in the previous tables must be installed.

The preceding statement must be included as a CAUTION statement in manuals for products operating with the approved antennas in the previous table to alert users on FCC RF Exposure compliance.

Any notification to the end user of installation or removal instructions about the integrated radio module is not allowed.

The radiated output power of PAN13xx with mounted ceramic antenna (FCC ID: T7V1315 or T7V1316) is far below the FCC radio frequency exposure limits. Nevertheless, the PAN13xx shall be used in such a manner that the potential for human contact during normal operation is minimized.

End users may not be provided with the module installation instructions. OEM integrators and end users must be provided with transmitter operating conditions for satisfying RF exposure compliance.

CLASSIFICATION	PRODUCT SPECIFICATION	No. DS-13xx-2400-102	REV. 5.1
SUBJECT	CLASS 1 or 2 BLUETOOTH MODULE	PAGE	52 of 55
CUSTOMER'S CODE PAN13XX Core Specification	PANASONIC'S CODE See Chapter Ordering Information	DATE	08.11.2017

31.2 INDUSTRY CANADA CERTIFICATION

31.2.1 IC Notice

This device complies with Industry Canada RSS-210 (Rev.8). Operation is subject to the following two conditions

- 1) this device may not cause interference, and
- 2) this device must accept any interference, including interference that may cause undesired operation of the device.

PAN131x is licensed to meet the regulatory requirements of Industry Canada (IC), license:

IC: 216Q-1315 (PAN1315, PAN1325)

IC: 216Q-1316 (PAN1316, PAN1317, PAN1326, PAN1327)

Manufacturers of mobile, fixed or portable devices incorporating this module are advised to clarify any regulatory questions and ensure compliance for SAR and/or RF exposure limits. Users can obtain Canadian information on RF exposure and compliance from www.ic.gc.ca.

This device has been designed to operate with the antennas listed in Tables 31.1.5 and 31.1.6 above, having a maximum gain of 1.3 dBi (PAN13x6: 0.9dBi). Antennas not included in this list or having a gain greater than 1.3 dBi (PAN13x6: 0.9dBi) are strictly prohibited for use with this device. The required antenna impedance is 50 ohms. The antenna used for this transmitter must not be co-located or operating in conjunction with any other antenna or transmitter. Due to the model size the IC identifier is displayed in the installation instruction.

Le présent appareil est conforme aux CNR d'Industrie Canada applicables aux appareils radio exempts de licence. L'exploitation est autorisée aux deux conditions suivantes :

- (1) l'appareil ne doit pas produire de brouillage, et
- (2) l'utilisateur de l'appareil doit accepter tout brouillage radioélectrique subi, même si le brouillage est susceptible d'en compromettre le fonctionnement.

PAN131x est garanti conforme aux dispositions réglementaires d'Industry Canada (IC), licences:

IC: 216Q-1315 (PAN1315, PAN1325)

IC: 216Q-1316 (PAN1316, PAN1317, PAN1326, PAN1327)

Il est recommandé aux fabricants d'appareils fixes, mobiles ou portables de consulter la réglementation en vigueur et de vérifier la conformité de leurs produits relativement aux limites d'exposition aux rayonnements radiofréquence ainsi qu'au débit d'absorption spécifique maximum autorisé.

Des informations pour les utilisateurs sur la réglementation Canadienne concernant l'exposition aux rayonnements RF sont disponibles sur le site www.ic.gc.ca.

Ce produit a été développé pour fonctionner spécifiquement avec les antennes listées dans le tableau ci-dessus, présentant un gain maximum de 1.3dBi (PAN13x6:0.9dBi). Des antennes autres que celles listées ici, ou présentant un gain supérieur à 1.3dBi (PAN13x6: 0.9dBi) ne doivent en aucune circonstance être utilisées en combinaison avec ce produit. L'impédance des antennes compatibles est 50Ohm. L'antenne utilisée avec ce produit ne doit ni être située à proximité d'une autre antenne ou d'un autre émetteur, ni être utilisée conjointement avec une autre antenne ou un autre émetteur. En raison de la taille du produit, l'identifiant IC est fourni dans le manuel d'installation.

CLASSIFICATION	PRODUCT SPECIFICATION	No. DS-13xx-2400-102	REV. 5.1
SUBJECT	CLASS 1 or 2 BLUETOOTH MODULE	PAGE	53 of 55
CUSTOMER'S CODE PAN13XX Core Specification	PANASONIC'S CODE See Chapter Ordering Information	DATE	08.11.2017

31.2.2 Labeling Requirements



The Original Equipment Manufacturer (OEM) must ensure that IC labelling requirements are met. This includes a clearly visible label on the outside of the OEM enclosure specifying the appropriate Panasonic IC identifier for this product as well as the IC Notice above. The IC identifiers are:

IC: 216Q-1315 (PAN1315, PAN1325)

IC: 216Q-1316 (PAN1316, PAN1317, PAN1326, PAN1327)

These IC identifiers are valid for all PAN13xx modules, for details, see the Chapter 29. Ordering Information. In any case the end product must be labelled exterior with "**Contains IC: 216Q-1315**" (PAN1315, PAN1325) or

"**Contains IC: 216Q-1316**" (PAN1316, PAN1317, PAN1326 and PAN1327).

Obligations d'étiquetage

Les fabricants d'équipements (OEM) doivent s'assurer que les obligations d'étiquetage du produit final sont remplies. Ces obligations incluent une étiquette clairement visible à l'extérieur de l'emballage externe, comportant l'identifiant IC du module Panasonic inclus, ainsi que la notification ci-dessus.

Les identifiants IC sont:

IC: 216Q-1315 (PAN1315, PAN1325)

IC: 216Q-1316 (PAN1316, PAN1317, PAN1326, PAN1327)

Ces identifiants sont valides pour tous les modules PAN13xx (Chapter 29. Ordering Information). Dans tous les cas les produits finaux doivent indiquer sur leur emballage externe une des mentions suivantes:

"**Contient IC: 216Q-1315**" (PAN1315, PAN1325) ou

"**Contient IC: 216Q-1316**" (PAN1316, PAN1317, PAN1326, PAN1327).

CLASSIFICATION	PRODUCT SPECIFICATION	No. DS-13xx-2400-102	REV. 5.1
SUBJECT	CLASS 1 or 2 BLUETOOTH MODULE	PAGE	54 of 55
CUSTOMER'S CODE PAN13XX Core Specification	PANASONIC'S CODE See Chapter Ordering Information	DATE	08.11.2017

31.3 EUROPEAN CONFORMITY ACCORDING TO RED (2014/53/EU)

All modules described in this Product Specification comply with the standards according to the following LVD (2014/35/EU), EMC-D (2014/30/EU) together with the RED (2014/53/EU) articles:

3.1a Safety/Health: EN60950-1:2006+A11:2009+A1:2010+A12:2011+AC:2011+A2:2013
EN62311:2008

3.1b EMC: EN 301 489-1 V2.1.1:2017-02
EN 301 489-17 V3.1.1:2017-02

3.2 Radio: EN 300 328 V2.1.1:2016-11

As a result of the conformity assessment procedure described in the 2014/53/EU Directive, the end customer equipment should be labelled as follows:



PAN13xx and its model versions in the specified reference design can be used in all countries of the European Economic Area (Member States of the EU, European Free Trade Association States [Iceland, Liechtenstein, Norway]), Monaco, San Marino, Andorra, and Turkey.

CLASSIFICATION	PRODUCT SPECIFICATION	No. DS-13xx-2400-102	REV. 5.1
SUBJECT	CLASS 1 or 2 BLUETOOTH MODULE	PAGE	55 of 55
CUSTOMER'S CODE PAN13XX Core Specification	PANASONIC'S CODE See Chapter Ordering Information	DATE	08.11.2017

31.4 JAPANESE RADIO LAW AND JAPANESE TELECOMMUNICATIONS BUSINESS LAW COMPLIANCE

This device is granted pursuant to the Japanese Radio Law (電波法).

This device should not be modified (otherwise the granted designation number will become invalid)

The following models are qualified for the Japanese market:

ENW89823A2KF MIC ID: [R]202-LSD072

ENW89823A3KF MIC ID: [R]202-LSD072

ENW89829A2KF MIC ID: [R]202-LSD073

ENW89829A3KF MIC ID: [R]202-LSD073

31.5 KOREAN CERTIFICATION

This device is granted pursuant to the Korean Law.

This device should not be modified (otherwise the granted designation number will become invalid).

1. Indicate the following expression on the product where it can be easily seen: "This radio equipment can be crossed during operation."

“該当の無線設備は運用の中で電波混信可能性がある”という文具を同設備のちゃんと見える所に表

示すること => “該当の無線設備は運用の中で電波混信可能性がある”

2. The manufacturer and installer should fully inform the operator or users: "This radio equipment cannot provide a service relevant to the human life safety, as it can be crossed" through the User Manual etc.

製作者及び設置者は当該の無線設備が電波混信可能性があるので人命安全と係わるサービスは出

来ないことをマニュアルなどを通じて運用者及び使用者に十分に知らせること

=> "該当の無線設備が電波混信可能性がありますので人命安全と係わるサービスは出来ません"

The MSIP number is: MSIP-CRM-Pid-ENW89823A3KF

This ID is valid for:

ENW89823A3KF

31.6 BLUETOOTH SIG STATEMENT

The Design is listed as Controller Subsystem with QDID: B019784

https://www.bluetooth.org/tpg/QLI_viewQDL.cfm?qid=19784

X-ON Electronics

Largest Supplier of Electrical and Electronic Components

Click to view similar products for [Bluetooth Development Tools \(802.15.1\) category:](#)

Click to view products by [Panasonic manufacturer:](#)

Other Similar products are found below :

[ENW89819AZKF](#) [CYBLE-212020-EVAL](#) [DVK-BT860-SA](#) [DVK-BT850-SA](#) [DVK-MSD50NBT](#) [SP14808ST](#) [DVK-BL600-SA-07](#) [DVK-BT860-ST](#) [DVK-BT850-ST](#) [MBH7BLZ02-EF-KIT](#) [CYBLE-014008-PROG](#) [FWM7BLZ20-EB-KIT](#) [SP14801-DUT](#) [ATSAMB11ZR-XPRO](#)
[EBWT11u](#) [SLWRB4306B](#) [SKY66111-21EK1](#) [QN9020DKUL](#) [CYBT-213043-EVAL](#) [QPK-NRF5X-01](#) [3026](#) [2267](#) [2479](#) [2487](#)
[DA14580DONGLE](#) [2633](#) [2995](#) [BMD-301-EVAL](#) [EBSHCNZWZ](#) [EBSHJNZWZ](#) [EKSHCNZWZ](#) [EKSHJNZWZ](#) [R41Z-TA-EVAL](#)
[CY8CKIT-062-BLE](#) [CYBLE-013025-EVAL](#) [CYBLE-214015-EVAL](#) [CYW920706WCDEVAL](#) [STEVAL-BLUEMIC-1](#) [STEVAL-](#)
[IDB007V1M](#) [EBSGJNAWY-WX](#) [EBSGCNAWY-WX](#) [AC320032-3](#) [ENW-89847AWKF](#) [UGWZ3AA001A](#) [STEVAL-IDB007V2](#) [CYBLE-](#)
[212006-EVAL](#) [DVK-BT800-02](#) [EBSHCNZXZ](#) [WSM-BL241-ADA-008DK](#) [SLWRB4303A](#)